



**BOROUGH COUNCIL AGENDA**  
**TUESDAY, FEBRUARY 13, 2024 – 7:00 P.M.**

Richard Mathews, Council President, presiding  
Pledge of Allegiance  
Roll Call

**REGULAR MEETING**

1. **Approval of Minutes: January 23, 2024, Regular Meeting Rescheduled from January 9, 2024**
2. **Open to the public**
  - a. Citizens wishing to comment will be recognized in the Order of their listing on the Appearance Sheet and are asked to stand up and give their name, address, and organization they represent (if applicable). Impromptu comments are limited to five minutes per individual.
  - b. Sewer Rate Increase – Resident Email
3. **Ordinances and Resolutions**
  - a. Ordinance #1-2024: Short Term Rental Regulations
  - b. Resolution #3-2024: Deed of Dedication – 1 Willow Trail
4. **Mayor's Report – R. Harris**
  - a. Police Report
  - b. Around Town
  - c. Upcoming Events & Meetings of Interest
  - d. In Requiem
5. **Fire/EMS/EMA Report**
6. **Committee Reports**
  - a. 2024 Committee Appointments
    - Committee Applicants
    - Nature Trail Ad Hoc Committee Recommendations
  - b. Planning Commission
7. **Administrative Business – Borough Manager**
  - a. Treasurer's Report – January 2024
  - b. Surplus Inventory Sale
  - c. Open Records Appeal – Final Determination
  - d. Confirmatory Deed
8. **Unfinished Business**
  - a. Grant Funding Updates
9. **New Business**
  - a. Proposed Zoning Amendment – Transitional Density Residential Overlay District
  - b. Eluma, Inc., - Agreement to Continue its Substantive Validity Challenge Before the ZHB
10. **Open to the public**
  - a. Citizens wishing to comment will be asked to stand up and give their name, address, and organization they represent (if applicable). Impromptu comments are limited to five minutes per individual.
11. **Adjournment**

## APPROVAL of MINUTES

---

# PUBLIC COMMENT

---

**From:** [Theresa Roberts](#)  
**To:** [David A. Hazlett](#)  
**Subject:** Sewer Rate Increase  
**Date:** Thursday, February 1, 2024 10:52:58 AM

---

**CAUTION:** This email originated from outside of the organization. Do not click links or open attachments unless you recognize the sender and know the content is safe.

Dave

Per our conversation here is my request:

My name is Theresa Roberts of 6 [REDACTED] Trl, Fairfield. I am a retired disabled Army Veteran of 28 yrs. I am seeking a military discount of some sort on the increased bill. I live on a very fixed income and am willing to supply any supporting documentation you require.

Thank You,  
Theresa Roberts  
[REDACTED]

# ORDINANCES and RESOLUTIONS

---

BOROUGH of CARROLL VALLEY  
ADAMS COUNTY, PENNSYLVANIA

Ordinance No. 1-2024

AN ORDINANCE OF THE BOROUGH OF CARROLL VALLEY, ADAMS COUNTY, PENNSYLVANIA, AMENDING CHAPTER 11 OF THE CARROLL VALLEY BOROUGH CODE OF ORDINANCES, ADDING A PART 2 TO REGULATE SHORT-TERM RENTALS.

BE IT ENACTED AND ORDAINED BY THE BOROUGH COUNCIL OF THE BOROUGH OF CARROLL VALLEY, ADAMS COUNTY, PENNSYLVANIA, THAT CHAPTER 11 WILL BE AMENDED TO THE CARROLL VALLEY BOROUGH CODE OF ORDINANCES AS FOLLOWS:

**WHEREAS**, Short-Term Rentals of Dwellings have become a significant segment of the local tourism economy; and

**WHEREAS**, Short-Term Rentals of Dwellings provide a community benefit by expanding the number and type of lodging facilities available and assist Owners of single-family homes by providing revenue which may be used for maintenance, upgrades, and deferred costs; and

**WHEREAS**, while the majority of these Short-Term Rentals operate without a problem, there have been complaints to the Borough regarding excessive noise, parking, litter, and concerns regarding security, public safety, and trespass; and

**WHEREAS**, the transitory nature of Occupants of Short-Term Rentals makes enforcement against the Occupants difficult; and

**WHEREAS**, the provisions of this Ordinance are necessary to prevent the continued burden on Borough and community services and impacts on residential neighborhoods posed by Short-Term Rentals; and

**WHEREAS**, the provisions of this Ordinance are necessary to provide for a system of inspections, the issuance and renewal of licenses, and to establish penalties for violations.

**NOW THEREFORE, BE IT ORDAINED AND ENACTED** by the Borough Council of Carroll Valley Borough, Adams County, Pennsylvania, pursuant to the above authority, as follows:

**SECTION 1.     SHORT TITLE.**

This Ordinance shall be known as “The Short-Term Rental Ordinance of Carroll Valley Borough.”

**SECTION 2.     AMENDMENT OF CHAPTER 11.**

Part 2 of Chapter 11, entitled: “SHORT-TERM RENTALS,” is hereby created and added to the Code of Ordinances of Carroll Valley Borough to provide as follows:

Part 2  
**SHORT-TERM RENTALS**

**§ 204-1. Title.**

This Chapter shall be known and may be cited as “The Short-Term Rental Ordinance of Carroll Valley Borough.”

**§ 204-2. Authority.**

Under the authority of the Pennsylvania Borough Code (including, but not limited to, Articles XII, XXXII-A, and XXXIII of such law including, but not limited to, Section 1202 subsections (1), (3), (4), (5), (8), (14) (15) (20) (61) and (65), Section 3204-A, and Section 3108), the following new ordinance text is hereby adopted as Part 2 of Chapter 11 in the Codified Ordinances of Carroll Valley Borough.

**§ 204-3. Scope.**

The provisions of this Chapter shall apply to all residential Dwelling Units, conversions of nonresidential structures to residential dwellings, and all existing premises within the Borough of Carroll Valley. The Owner of the subject premises shall be responsible for compliance with the provisions of this Chapter, and the Owner, Manager, or renting occupants’ failure to comply with this Chapter’s requirements shall be deemed noncompliance by the Owner.

**§ 204-4. Definitions.**

As used in this Chapter, the following terms shall have the following meanings. If a term is not defined in this Chapter but is defined in the Borough’s Property Maintenance/Nuisance Code or Uniform Construction Codes, then that definition shall apply to this Chapter. If a term is not defined in any of those codes but is defined elsewhere in the Borough Code, then the definition in such Chapter shall apply to this Chapter.

**BEDROOM** -- A room or space designed for sleeping purposes with two means of egress and in close proximity to a bathroom. Space used for eating, cooking, bathrooms, toilet rooms, closets, halls, storage or utility rooms, and similar uses are not considered bedrooms. Space used or intended for general and informal everyday use, such as a living room, den, sitting room, or similar, is not considered a bedroom.

**CODE ENFORCEMENT OFFICER (CEO)** -- The Borough-appointed Code Enforcement Officer is responsible for enforcing this Chapter and the Code and any assistants or deputies appointed by the Borough, including police officers. At the discretion of the Borough Council, an independent entity or contractor may be appointed to enforce part or all of this function under this Chapter.

**DWELLING UNIT** -- One or more rooms, occupied or intended for occupancy, as separate living quarters by a single family maintaining a household, the members of which have unrestricted access to all other parts thereof, with cooking, sleeping, and sanitary facilities provided therein, for the exclusive use of that single family. For the purposes of this Chapter, this term shall be used when referring to dwellings and/or dwelling units, as defined under the Zoning Ordinance, and shall include guesthouses.

FAMILY-- One or more individuals related by blood, marriage, or adoption (including persons receiving formal foster care) or up to four (4) total unrelated individuals who maintain a common household and live within one Dwelling Unit, except as provided otherwise in the Code. For this purpose, "related" shall mean persons who are related by blood, marriage, adoption, civil union recognized by any state, or formal foster relationship to result in one of the following relationships: spouse, brother, sister, parent, child, grandparent, great-grandparent, grandchild, great-grandchild, uncle, aunt, niece, nephew, sister-in-law, brother-in-law, parent-in-law or first cousin. "Step" relationships shall also be included, such as stepmother. "Related" shall not include any relationship further than direct first cousins.

Notwithstanding the above definition, a family shall also be deemed to include any number of mentally or physically disabled persons occupying a dwelling unit as a single, nonprofit housekeeping unit if such occupants are disabled persons as defined in Title VIII of the Civil Rights Act of 1968, as amended by the Fair Housing Amendments Act of 1988. Such unrelated individuals shall have the right to occupy a Dwelling Unit in the same manner and to the same extent as any family unit as defined above.

LOCAL CONTACT PERSON — A person or agent with actual authority to represent the Owner for purposes of contact and communication regarding the Owner's Short-Term Rental. A local contact person must be able to respond and arrive at the Short-Term Rental property within one hour of notice and must be authorized to act as a legal agent for the Owner. If there is a change in the identity of the local contact person, the Borough must be notified, in writing, within 14 days or prior to the Rental of the property if the Rental occurs within said fourteen-day period.

SHORT-TERM RENTAL — Any Residential Dwelling Unit utilized as a single-family residence rented for the purpose of overnight lodging for a period of not less than one (1) day and not more than thirty (30) days and which is registered with the Adams County Treasurer's Office in compliance with County Ordinance No. 3 of 2012 for the payment of Hotel Room Rental Tax, as may be reenacted or amended.

SHORT-TERM RENTAL LICENSE — Permission granted by the Borough to utilize a Dwelling Unit for Short-Term Rental use.

#### **§ 204-5. License Required.**

No Owner of any Premises in Carroll Valley Borough shall operate a Short-Term Rental in Carroll Valley Borough without first obtaining a Short-Term Rental License from the Code Enforcement Officer. Operation of a Short-Term Rental without a Short-Term Rental License is a violation of this Chapter.

#### **§ 204-6. License Requirements.**

- A. Application requirements. Short-Term Rental License applications shall contain the following information:
1. The name, address, telephone number, and email address of the Owner. If the Owner is not a full-time resident of the Borough of Carroll Valley or does not live or have a primary physical work address (beyond a post office box) within a twenty-mile radius of the Borough



of Carroll Valley, then the Owner shall designate a Person to serve as Manager who does reside or have a primary physical work headquarters (beyond a post office box) within a twenty-mile radius of the Borough of Carroll Valley. If the Owner is a corporation, partnership, or similar entity, a Manager shall be appointed to meet the above requirements. If the Owner is not required to have or has not designated a Manager, then the Owner shall provide a 24-hour telephone number. If the Owner uses a Manager, that Manager shall have written authorization to accept service for the Owner.

2. The name, address, and 24-hour telephone number of the Manager.
  3. Total habitable floor space and total number of bedrooms for the short-term rental.
  4. If the building is a multi-dwelling unit structure, the total number of dwelling units in the structure and the number of dwelling units being used as Short-Term Rentals. Each Dwelling Unit in a multi-dwelling unit structure must have a separate Short-Term Rental License.
  5. A site plan showing property lines, driveways, and all structures, including the location and number of on-site parking spaces. An on-site inspection will be required to verify available parking spaces and consistency with the submitted site plan.
  6. Septic system evaluation certifying the existing system is functioning as intended and proof the tank was pumped within the past three (3) years for approval by the Sewage Enforcement Officer. An inspection of the on-lot sewage disposal system to verify consistency with the submitted site and floor plans may be required.
  7. Copies of the current Adams County Hotel Room Excise Tax Certificate and current Pennsylvania Sales and Use Tax License.
  8. Signatures of both the Owner and the Manager.
  9. Copy of the current recorded Deed for the Premises establishing ownership may be required.
  10. No permit will be issued to any owner who is delinquent with Borough sewer fees or property taxes for all properties owned, in whole or in part, by the Owner in the Borough. If sewer fees or property taxes become delinquent after the issuance of a Short-Term Rental permit, the permit will be revoked until such time as the delinquent account is brought current.
  11. Short-term rental owners must provide weekly trash removal. No dumpsters are permitted.
  12. A statement by the owner that there are no delinquent Adams County Hotel Room Excise Tax or Pennsylvania sales/use taxes due and owing with respect to Short-Term Rentals on all properties owned, in whole or in part, by the Owner in the Borough.
- B. A Short-Term Rental License shall be issued only to the Owner of the Short-Term Rental Premises.

1. A separate Short-Term Rental License is required for each Dwelling Unit; for two-family or multi-family dwellings, a separate License shall be required for each Dwelling Unit being used as a Short-Term Rental.
2. A Short-Term Rental License is effective for one (1) year or until any of the conditions of the Short-Term Rental governed by this Chapter are changed, whichever shall first occur. A Short-Term Rental License must be renewed annually, and also when any of the conditions of the Short-Term Rental which are governed by this Chapter are changed.
3. The Owner, by making an application for a Short-Term Rental License and/or accepting issuance of a Short-Term Rental License, grants permission for any and all inspections authorized by this part.
4. The Borough will prescribe forms and procedures for processing License applications under this Ordinance.

**§ 204-7. Short-Term Rental Standards.**

- A. Overnight occupancy of a Short-Term Rental shall be limited to no more than two (2) persons per bedroom plus four (4) additional persons.

Number of Bedrooms	Maximum Number of Occupants
2	8
3	10
4	12
5	14

- B. The maximum number of day guests allowed at any one time, in addition to the overnight occupants, shall be fifty percent (50%) of the maximum overnight occupancy of the Short-Term Rental.
- C. For Short-Term Rentals using an on-site septic system, the number of bedrooms permitted for a Short-Term Rental shall not exceed the number of bedrooms approved for the Dwelling Unit on the sewage permit issued for such property. Where there is no sewage permit on record, the Short-Term Rental shall be limited to three (3) bedrooms unless proof is provided to the Sewage Enforcement Officer that the septic system is adequate to handle additional flows. Any Short-Term Rental advertising more than five (5) bedrooms shall provide proof that the septic system is adequate to handle such flows by having the system approved by the Sewage Enforcement Officer or by providing a septic permit previously issued by a Sewage Enforcement Officer. If a sewage system malfunction occurs, the Short-Term Rental of the Dwelling Unit shall be discontinued until the malfunction is corrected in accordance with Borough and Pennsylvania Department of Environmental Protection requirements.
- D. Off-street parking areas for Short-Term Rental uses must meet the Zoning Ordinance requirements for single-family dwellings. Day visitors must park according to the on-street

parking requirements for that street. Overnight guests must park in an approved off-street parking area, not on the street. Any expansion of parking areas for a Short-Term Rental requires prior Borough approval. Parking areas shall be maintained in a mud-free condition with paving, stone, or similar material and shall count as part of the maximum lot coverage limits in Chapter 27.

- E. Short-Term Rental Premises are considered a commercial account in the Borough's sanitary sewer collection service; Short-Term Rental Premises must have a commercial sanitary sewer account for each rental unit on the property.
- F. Neither Short-Term Rental Occupants nor guests shall engage in disorderly conduct or disturb the peace and quiet of any nearby neighborhood or person by loud, unusual, or excessive noise, by tumultuous or offensive conduct, public indecency, threatening, traducing, quarreling, challenging to fight, or fighting, or creating a dangerous or physically offensive condition.
- G. The Owner shall notify the Occupants of the rules regarding Short-Term Rentals and respond when notified that occupants violate laws, ordinances, or regulations regarding their occupancy.
- H. Overnight occupancy of recreational vehicles, camper trailers, and tents at the property where the Short-Term Rental is located shall not be allowed. Outdoor overnight sleeping of occupants or guests of the Short-Term Rental is prohibited.
- I. A Short-Term Rental shall not have any outside appearance indicating a change of use from the surrounding residential uses. Exterior advertising shall conform with the requirements of Chapter 27
- J. All Short-Term Rentals shall have a visible and legible notice posted conspicuously within the dwelling unit containing the following information:
  - 1. The name of the Owner or the Manager of the unit and a telephone number at which that party can be reached on a 24-hour basis.
  - 2. The 911 address of the Premises.
  - 3. The maximum number of Occupants permitted to stay in the Dwelling Unit and the maximum number of day guests permitted at any one (1) time.
  - 4. The maximum number of all vehicles allowed to be parked on the Premises and the requirement that all overnight guest parking must be on the Premises and not in or along any private, community, or public street right-of-way or on any lawn or vegetated area on the property.
  - 5. Notification that an Occupant or guest may be cited and fined for creating a disturbance or for violating other provisions of the Carroll Valley Borough Code of Ordinances, including parking and occupancy limits.

6. The trash pick-up day and notification that trash and refuse shall not be left or stored on the property's exterior, including instructions for where and when to place the trash for pickup.
- K. All short-term rentals shall be equipped with the following:
1. Smoke detectors in each bedroom;
  2. Smoke detectors outside each bedroom in common hallways;
  3. Smoke detectors on each floor;
  4. GFI outlets for outlets located within six feet of water source;
  5. Aluminum or metal exhaust from the dryer, if provided for tenant use;
  6. Carbon monoxide detector if open flame (oil or gas) furnace, gas or wood fireplace, or wood-burning stove;
  7. Carbon monoxide detector, if a garage is attached;
  8. Fire extinguisher in kitchen;
  9. Stairs (indoor and outdoor) in good condition and
  10. Swimming pools, hot tubs, and spas must meet the barrier requirements as required by the current edition of the PA Uniform Construction Code; and
- L. The Owner shall not enter into a rental agreement with a person under 18 years of age.
- M. Owner's Compliance with the requirements of this section shall be considered conditions of a short-term rental permit. Violation of any of the requirements of this section shall be grounds for revocation of the short-term rental permit by the Code Enforcement Officer. In the event that more than one short-term Rental is located on a single property, and any one short-term Rental is in violation of any of the requirements of this section, all permits associated with the property may be revoked.
- N. The Owner must guarantee continued compliance with Chapter 10. Any violation of Chapter 10 may cause the revocation of the Short-term Rental Permit for a minimum of 12 months, but no longer than 36 months, at the discretion of the Code Enforcement Officer.

**§ 204-8. Fees, Term, and Renewal.**

- A. Short-Term Rental License fees, payable to the Borough upon the filing of a Short-Term Rental License application, shall be in such amount as may be established by resolution duly adopted by the Borough Council.
- B. Any Short-Term Rental License is valid for a period not to exceed one (1) year from the date of issuance and must be renewed annually. Short-Term Rental License renewal fees, payable to the Borough upon filing a Short-Term Rental License renewal application, shall be in such amount as may be established by resolution duly adopted by the Borough Council from time to time.
  1. Short-Term Rental License renewal shall require inspections outlined in Section 204-10 below.

2. Short-Term Rental License renewal applications shall contain information regarding any changes from the immediately preceding application with respect to matters governed by this Ordinance.

**§ 204-9. Enforcement Officer.**

The Carroll Valley Borough Code Enforcement Officer and/or other appointed official shall conduct inspections, make reports, administer this Chapter, and issue notices of violation.

The Code Enforcement Officer and/or other appointed official, with the authorization of the Borough Council, may engage the services of competent engineers or other consultants to determine the nature and extent of any violation.

**§ 204-10. Annual Inspections Required.**

- A. All Short-Term Rentals shall be subject to an annual inspection by the Code Enforcement Officer to verify application information, License, License renewal, and/or operating requirements. All Short-Term Rentals shall be inspected to meet the full requirements of the Borough's adopted Property Maintenance and Nuisance Codes.
- B. The issuance of a Short-Term Rental License or inspection is not a warranty that the Premises is lawful, safe, habitable, or in compliance with this Chapter of the Code of Ordinances. Rather, the license indicates that the Premises are either set to be inspected on a routine basis or, if inspected, the Premises met this Chapter of the Code of Ordinance requirements on the day and at the time of the inspection.
- C. Within the limitations of federal and state law, the Code Enforcement Officer may apply to a Magisterial District Judge or any legal authority having jurisdiction for an administrative search warrant to enter and inspect a Short-Term Rental Unit and the Premises. Such warrant is only required where access to a Short-Term Rental Unit or common areas is denied to the Code Enforcement Officer after a request to a person with a possessory interest in the regulated rental unit.

**§ 204-11. Marketing.**

The marketing of a Short-Term Rental in which the advertised occupancy exceeds the maximum occupancy requirements permitted by this Chapter or which promotes any other activity prohibited by this Chapter shall be a violation of this Chapter.

**§ 204-12. Notice of Violation.**

If it appears to the Code Enforcement Officer that a violation of this Chapter exists or has occurred, the Code Enforcement Officer shall send a written Notice of Violation to the Owner and/or Manager (if one is so designated) by personal delivery or by both United States first class and certified mail. The Enforcement Notice shall identify the Premises which is the subject of the violation, enumerate the conditions which constitute the violation, cite the specific sections of this Chapter that are violated,

indicate the action required to correct the violation and provide a time frame (established by the Code Enforcement Officer based upon the nature of the violation) to correct the violation.

**§ 204-13. Nuisance.**

In the interest of promoting public health, safety, and welfare and minimizing the burden on Borough and community services and impacts on community neighborhoods posed by Short-Term Rentals, a violation of any of the provisions of this Chapter is declared to be a public nuisance.

**§ 204-14. Violations and penalties.**

- A. This Chapter shall be enforced by action brought before a Magisterial District Judge in the same manner provided for the enforcement of summary offenses under the Pennsylvania Rules of Criminal Procedure. Any Person, partnership, corporation, or other entity that violates or permits a violation of the provisions of this Chapter shall, upon conviction in a summary proceeding, pay a fine of not less than \$100 nor more than \$1,000 per violation, plus all court costs and reasonable attorney's fees incurred by Carroll Valley Borough in the enforcement proceedings, and/or be imprisoned to the extent allowed by law for the punishment of summary offenses. Each day or portion thereof that a violation exists or continues shall constitute a separate violation. Further, Carroll Valley Borough's appropriate officers or agents are hereby authorized to seek equitable relief, including injunction, to enforce compliance with this Chapter. All fines, penalties, costs, and reasonable attorneys' fees collected for the violation of this Chapter shall be paid to Carroll Valley Borough for its general use.
- B. In addition to, but not in limitation of, the provisions of the Part, the Code Enforcement Officer may either revoke or deny an application to renew a Short-Term Rental License for three (3) violations of this Chapter for any owner in any rolling twelve (12) calendar month period.
- C. The revocation or denial to renew a Short-Term Rental License shall continue for six (6) months for the first set of three (3) violations and continue for one (1) year for any subsequent sets of violations.

**§ 204-15. Owner's Severally Responsible.**

If more than one Owner owns the premises, each Owner shall jointly and severally be responsible for violations of this Chapter.

**§ 204-16. Appeals.**

Appeals of a determination of the Code Enforcement Officer under this Chapter to deny any application for, or to renew, a Short-Term Rental License or to revoke a Short-Term Rental License shall be filed with the Borough Council at the Borough business office within thirty (30) days of the date of the determination appealed from.

**§ 204-17. Severability.**

If any section, provision, or portion of this Ordinance shall be held invalid or unconstitutional by any Court of competent jurisdiction, such decision shall not affect any other section, clause, provision, or

portion of this Ordinance so long as it remains legally enforceable minus the invalid portion. The Borough reserves the right to amend this Ordinance or any portion thereof from time to time as it shall deem advisable in the best interest of the promotion of the purposes and intent of this Ordinance and the effective administration thereof.

**§ 204-18. Repealer.**

All Ordinances or parts of Ordinances which are inconsistent herewith are hereby repealed.

**§ 204-19. Effective date.**

This Ordinance shall become effective upon the earliest date provided by law.

ORDAINED AND ENACTED as an Ordinance of the Borough of Carroll Valley this \_\_\_ day of \_\_\_\_ 20\_\_.

ATTEST:

CARROLL VALLEY BOROUGH COUNCIL

\_\_\_\_\_  
Secretary

\_\_\_\_\_  
Council President

\_\_\_\_\_  
Mayor

**CERTIFICATION OF ADOPTION**

I hereby certify that the foregoing Ordinance was advertised in the Gettysburg Times, a newspaper of general circulation in the Borough, on \_\_\_\_\_, and was duly enacted and approved at a meeting of the Borough Council of the Borough of Carroll Valley on \_\_\_\_\_.

Gayle Marthers  
Assistance Borough Manager / Borough Secretary

**BOROUGH OF CARROLL VALLEY  
ADAMS COUNTY, PENNSYLVANIA**

**RESOLUTION**

**A RESOLUTION OF THE BOROUGH OF CARROLL VALLEY, ADAMS COUNTY, PENNSYLVANIA ACCEPTING THE DEDICATION OF A PARCEL OF LAND MEASURING 0.54 ACRE OWNED BY E. ALLEN AHEARN AND ESTHERE A. AHEARN AND IDENTIFIED AS TAX PARCEL ID NO. 43005-0066---000 (“LOT J-0016”).**

**WHEREAS**, pursuant to Section 1201(4) of the Borough Code, 8 Pa.C.S.A. §1201(4), the Borough of Carroll Valley (the “Borough”) may purchase, exchange, acquire by gift, or otherwise hold, lease, let and convey, by sale or lease, real and personal property deemed to be in the best interest of the Borough; and

**WHEREAS**, pursuant to Section 3301.1(d) of the Borough Code, 8 Pa.C.S.A. § 3301.1(d), approval of the acquisition, disposition and leasing of real or personal property shall be by adoption of a resolution; and

**WHEREAS**, E. Allen Ahearn and Esthere A. Ahearn own land measuring 0.54 acre, located at 1 Willow Trail, Carroll Valley, Pennsylvania, identified as tax parcel ID No. 43005-0066---000 (“LOT J-0016”); and more fully described in the legal description attached hereto as Exhibit “A” and incorporated herein by reference; and being the same real estate that Charnita Ski Area, Inc. conveyed to E. Allen Ahearn and Esthere A. Ahearn, by a deed May 15, 1969, and recorded on October 18, 1969, in Deed Book 278, Page 633, in the Office of the Recorder of Deeds for Adams County, Pennsylvania; and

**WHEREAS**, E. Allen Ahearn and Esthere A. Ahearn desire to dedicate 1 Willow Trail to the Borough; and

**WHEREAS**, the Borough Council deems it in the best interest of its citizens and the general public to accept the dedication of 1 Willow Trail; and

**WHEREAS**, the Borough intends to use Lot J-0016 for municipal recreational purposes; and

**NOW THEREFORE**, be it resolved by the Council of the Borough of Carroll Valley as follows:

1. The recitals referenced above are incorporated herein by reference hereto.



2. The Council of the Borough of Carroll Valley authorizes the acceptance of 1 Willow Trail subject to the Borough Manager and Borough Solicitor being satisfied that any conditions associated with the Deed of Dedication have been satisfied by E. Allen Ahearn and Esthere A. Ahearn, including the requirement that E. Allen Ahearn and Esthere A. Ahearn remit all costs associated with the exchange.
3. This Resolution shall become effective immediately.
4. The provisions of this Resolution shall be severable, and if any of its provisions shall be held to be unconstitutional, illegal, or invalid, such unconstitutionally, illegality, or invalidity shall not affect the validity of any of the remaining provisions of this Resolution.
5. All other Resolutions or parts of Resolutions inconsistent herewith are hereby repealed.

**DULY ADOPTED**, pursuant to the authority granted to the Borough of Carroll Valley under the laws of the Commonwealth of Pennsylvania in lawful session duly assembled on this \_\_\_\_\_ day of \_\_\_\_\_, 2024.

**BOROUGH OF CARROLL VALLEY**

By: \_\_\_\_\_

Richard Mathews, Borough Council President

**ATTEST:**

\_\_\_\_\_  
(SEAL)

Gayle Marthers, Borough Secretary

**Exhibit A**  
**1 Willow Trail**

All that tract of land situate, lying and being in the Borough of Carroll Valley (erroneously described in Hamiltonban Township in prior deed), Adams County, Pennsylvania, being Lot No. 16 in Section J. bounded and described as follows:

BEGINNING at a point in the center of Blue Ridge Trail at Lot No. 15; thence by said lot South 86 degrees 48 minutes 20 seconds West, 124.18 feet to Lot No. 17; thence by said lot North 3 degrees 11 minutes 40 seconds West, 194.40 feet to a point in the center of Willow Trail; thence in said Willow Trail South 86 degrees 37 minutes East, 125 feet to a point in the intersection of Willow Trail and Blue Ridge Trail; thence in said Blue Ridge Trail South 3 degrees 11 minutes 40 seconds East, 180.08 feet to the place of BEGINNING.

The above description was taken from a plan of lots labeled "Section J, Charnita Ski Area, Inc.:" dated March 20, 1968, prepared by Gordon L. Brown, R.S., recorded in Adams County Plat Book No. 1 at page 24.

Being part of the same which Charnita Ski Area, Inc. by deed dated May 15, 1969, and recorded on October 18, 1969 in the Office of the Recorder of Deeds for Adams County, Pennsylvania, in Deed Book 278, Page 637, conveyed unto E. Allen Ahearn and Esthere A. Ahearn, the Grantors herein named.

Together with a right of way and easement over the private roads indicated on said lot plan recorded in Adams County Plat Book no. 1 at Page 24 for means of ingress and regress.

Reserving however, unto the Grantors, its successors and assigns, a right of way and easement over said private roads indicated on said lot plan recorded in Adams County Plat Book No. 1 at page 24, to be used forever in common with the grantees, their heirs and assigns, for means of ingress, egress and regress.

SUBJECT TO THE ATTACHED RESTRICTIONS

#### SCHEDULE OF RESTRICTIONS

The following regulations governing the buildings that may be erected on your property, and their use, are instituted for your protection. Many places of beauty have been marred by failure to provide property protective restrictions.

#### REGULATIONS AND RESTRICTIONS

ARCHITECTURAL COMMITTEE	No structure of any kind or construction of any sort shall be placed or constructed upon this property unless and until plans . descriptions of same shall have been submitted to, and approved in writing by the Architectural Committee appointed by Charnita Ski Ar
TRAILERS AND TEMPORARY BUILDINGS	Except with the written consent of the Architectural Committee no structure, tent, trailer, or their living quarters, temporary permanent shall be placed upon any part of the property.
DESIGN AND MATERIALS	Buildings may be of a contemporary period or modern design, and may be constructed of wood, stone, brick, or composition be finished or painted in such a manner as not to detract from, or mar the natural beauty of the surroundings.
TOILET FACILITIES	No outhouses shall be permitted on any part of the property. All toilet facilities must be within the main dwelling.
BUILDING LINES	No structure may be placed nearer than 30 feet from the road right of way or nearer than 10 feet from any adjacent lot.
FLOOR AREA	No one-floor dwelling shall be built unless it contains a minimum ground floor area of 800 square feet exclusive of porches and the side nearest the road is to be at least 30 feet wide. No multiple floored dwelling shall be built with less than 900 square exclusive of porches and patios. "A" Line homes are excepted, and the minimum frontage shall be 28 feet.
NUMBER OF BUILDINGS	No more than one building may be erected on any one lot except on lots designated for multiple units.
GARAGES	Garages, carports or car shelters, if built shall be attached to a part of the main dwelling where possible.
FIRES AND CHIMNEYS	No open fire shall be permitted on any part of the property. Outdoor fireplaces if built, and all chimneys shall be provided with screens.
USE OF BUILDINGS	No building shall be used for any other residential purposes (except on lots designated by the subdividers as commercial lots: offensive trade or other activity shall be carried on, on said lot, nor shall anything be done thereon which may constitute or become a nuisance or annoyance or nuisance.
TREES	No trees over two inches in diameter shall be cut down without the permission of the Architectural Committee.
SIGNS	No signs shall be erected, permitted, or maintained upon the property without the written consent of the Committee.
GARBAGE AND TRASH	Garbage must be kept in covered metal containers, or buried, and trash, tin cans, bottles, paper, etc., shall be kept in wire or containers or buried.

GUNS AND SHOOTING	No rifle, shotgun or small arms shooting shall be permitted anywhere upon the property, except in areas reserved and designed the same.
WATER	Since no commercial enterprises will be permitted which could destroy the desirability and beauty of this natural woodland, reserves all oil, water, and mineral rights. However, this does not prohibit the development of a water well for private use, except where water is provided. At such time as a public or private water company is available, the hookup fee shall not exceed \$250.00
ROADS	All roads and driveways on the Charnita Ski Area Subdivision Plan are to remain in private, to be used by lot owners and tenants only. Road maintenance costs shall be prorated between property owners serviced, fronting on, or benefited by such roads. The cost shall not exceed \$25.00 per year per lot.
RIGHTS OF WAY FOR UTILITIES	There is reserved by the Seller, its successors and assigns forever, a right of way along all road rights of way of a uniform width measured from the road right of way toward the rear property line of each lot together with a 6-foot right of way along all side perimeter lines to enter upon, over and across said right of way for the construction, operation, and maintenance of pole line electric and telephone service and other utilities. Seller reserves the sole right to convey the rights hereby conveyed.
ANIMALS	No poultry, horse, cow, sheep, hog goat or other similar animals, excepting only ordinary, household pets, shall be kept or permitted on the premises.
INGRESS AND EGRESS	No lot may be used for ingress or egress to any other property other than a Charnita Ski Area Inc, subdivision without the written permission of Charnita Ski Area Inc.
DOCKS AND QUAYS	No structure, pier or quay may be extended more than ten feet beyond the shore line of lakes, or be placed in the waters of the lakes.
MAINTENANCE OF LAKES AND STREAMS	With respect to every lot fronting upon or abutting a lake or stream, there is reserved by the Seller, its successors and assigns the right to raise or lower the water level by artificial means a distance of not more than 15 feet as well as the right to ingress, egress, approach to, from and along the water's edge for the purpose of maintaining the streams and lakes.

Exceptions and reservations referred to in the foregoing above Schedule of Restrictions are excepted and reserved unto the grantor, its successors and assigns forever with respect to the section mentioned therein within deed.

# MAYOR'S REPORT

---



# January 2024 Police Report



by  
Chief Clifford J. Weikert  
Carroll Valley Borough Police

## Special News / Achievements:

- The Carroll Valley Civil Service Commission will be meeting at the end of January to decide on two candidates that have passed their written exam, oral exam, and physical fitness exam. I hope to have our fourth officer ready for appointment by our March meeting. Jonathan Anderson has passed all of his requirements for his conditional offer and will start on January 19<sup>th</sup>.



## Around Town:

Anyone looking for a used car? After approval from the council, we will be putting up for bid two used cruisers on [www.municibid.com](http://www.municibid.com).

The screenshot shows the Municibid website interface. At the top, there is a navigation bar with 'Home', 'Browse', 'About', and 'Help'. On the right, there are links for 'Sell', 'Hi David!', '0 My Municibid', and 'Sign Out'. The main content area is titled 'DRAFTS'. Below this, there is a 'Filter By' section with radio buttons for 'Title' and 'Listing #', and a 'Filter' button. To the right of the filter is a 'Sort' dropdown menu set to 'Newest'. Below the filter and sort options, there is a 'Select All' checkbox and an 'Activate Selected' button. The main area displays two draft listings for '2014 DODGE CHARGER POLICE CRUISER HEMI'. Each listing includes a photo of the car, the title, a unique ID number, the ending time, and the starting bid of \$5,000.00. Below each listing are buttons for 'Activate Listing', 'Edit', 'List Similar', and 'Delete'.

## Crime Data:

Key to reading the following page:

1. At the top left, you see overall statistics for the month. Total offenses and clearance rate refer to Group "A" offenses. Arrests refer to Group "A" and Group "B". This data is only for Carroll Valley Borough.
2. It also includes crime rates and arrest rates, however this calculation is not yet functioning on the PA State Police system, so they display as -0-. When working correctly, they will report in the national standard of per 100,000 population. As such, when it does calculate, it shows the rate as if the Carroll Valley population was 100,000. By doing this, it makes the rate comparable regardless of the size of the jurisdiction.
3. The column below on the left shows all Group "A" offenses. Offenses can be generally cleared by:
  - a. Arrest (by charging someone with the crime).
  - b. Victim Refused Prosecution = Prosecution limited by victim, or;
  - c. Exceptional Clearance = Charges could be filed but for cause are not.
4. In the center, NIBRS adds additional categories, and you can see how they compare year over year for the month reported.
5. On the right column, you first see a list of arrests for Group "A" offenses, divided into adults and juveniles.
6. At the bottom of the right column, Group "B" arrests are listed. As a major change in NIBRS reporting, Group "B" offenses are only listed when an arrest occurs. Unsolved Group "B" offenses are no longer reported.
7. Each NIBRS offense belongs to one of three categories: Crimes Against Persons, Crimes Against Property, and Crimes Against Society. Crimes Against Persons, e.g., murder, rape, and assault, are those whose victims are always individuals. The object of Crimes Against Property, e.g., robbery, bribery, and burglary, is to obtain money, property, or some other benefit. Crimes Against Society, e.g., gambling, prostitution, and drug violations, represent society's prohibition against engaging in certain types of activity; they are typically victimless crimes in which property is not the object.



# Offense and Arrest Summary Report

Printed On: 02/08/2024

Beginning Date: 01/01/2024

Ending Date: 01/31/2024

Page 1 of 1

Agency: CARROLL VALLEY BOROUGH

Municipality: Carroll Valley Borough

Total Offenses 5 Clearance Rate 20%  
 % change from last year -44.44% Last years rate 22.22%

Total Arrests 2 Hate Crime Offenses  
 % change from last year 0% Law Officers Assaulted

Group A Crime Rate per 100,000 Population : 111.48 Summary based reporting 111.48  
 Crime Rate per 100,000 Population :

Arrest Rate per 100,000 Population : 44.59

### Offense Reporting

Group "A"	Offenses Reported	Offenses Cleared	Offenses Reported Last Year
Murder	0	0	0
Nagligent Manslaughter	0	0	0
Justifiable Homicide	0	0	0
Rape	0	0	0
Robbery	0	0	0
Aggravated Assault	0	0	0
Burglary	0	0	0
Larceny	4	0	6
Motor Vehicle Theft	1	1	0
Arson	0	0	0
Simple Assault	0	0	0
Intimidation	0	0	0
Bribery	0	0	0
Counterfeiting/Forgery	0	0	0
Vandalism	0	0	0
Drug/Narcotic Violations	0	0	0
Drug Equipment Violations	0	0	1
Embezzlement	0	0	0
Extortion/Blackmail	0	0	0
Fraud	0	0	1
Gambling	0	0	0
Kidnapping	0	0	0
Pornography	0	0	0
Prostitution	0	0	0
Sodomy	0	0	0
Sexual Assault w/Object	0	0	0
Fondling	0	0	0
Incest	0	0	0
Statutory Rape	0	0	1
Stolen Property	0	0	0
Weapons Law Violations	0	0	0
Human Trafficking, Commercial Sex Acts	0	0	0
Human Trafficking, Involuntary Servitude	0	0	0
Animal Cruelty	0	0	0
<b>Total Group "A"</b>	<b>5</b>	<b>1</b>	<b>9</b>

Population : 4485

Note: Last years figures are provided for comparison purposes only.

### Crime Against Person

0 - This year  
 1 - Last year  
 -100% - Percent Change

### Crime Against Property

5 - This year  
 7 - Last year  
 -28.57% - Percent Change

### Crime Against Society

0 - This year  
 1 - Last year  
 -100% - Percent Change

### Arrest Reporting

Group "A"	Adult	Juvenile	Unknown	Total Arrests	Arrests Reported Last Year
Murder	0	0	0	0	C
Negligent Manslaughter	0	0	0	0	C
Justifiable Homicide	0	0	0	0	C
Rape	0	0	0	0	C
Robbery	0	0	0	0	C
Aggravated Assault	0	0	0	0	C
Burglary	0	0	0	0	C
Larceny	0	0	0	0	C
Motor Vehicle Theft	1	0	0	1	C
Arson	0	0	0	0	C
Simple Assault	0	0	0	0	C
Intimidation	0	0	0	0	C
Bribery	0	0	0	0	C
Counterfeiting/Forgery	0	0	0	0	C
Vandalism	0	0	0	0	C
Drug/Narcotic Violations	0	0	0	0	C
Drug Equipment Violations	0	0	0	0	1
Embezzlement	0	0	0	0	C
Extortion/Blackmail	0	0	0	0	C
Fraud	0	0	0	0	C
Gambling	0	0	0	0	C
Kidnapping	0	0	0	0	C
Pornography	0	0	0	0	C
Prostitution	0	0	0	0	C
Sodomy	0	0	0	0	C
Sexual Assault w/Object	0	0	0	0	C
Fondling	0	0	0	0	C
Incest	0	0	0	0	C
Statutory Rape	0	0	0	0	C
Stolen Property	0	0	0	0	C
Weapons Law Violations	0	0	0	0	C
Human Trafficking, Commercial Sex Acts	0	0	0	0	C
Human Trafficking, Involuntary Servitude	0	0	0	0	C
Animal Cruelty	0	0	0	0	C
<b>Total Group A Arrests</b>	<b>1</b>	<b>0</b>	<b>0</b>	<b>1</b>	<b>1</b>
<b>Group "B" Arrests</b>					
Bad Checks	0	0	0	0	0
Curfew/Vagrancy	0	0	0	0	0
Disorderly Conduct	1	0	0	1	0
DUI	0	0	0	0	1
Drunkenness	0	0	0	0	0
Family Offenses-nonviolent	0	0	0	0	0
Liquor Law Violations	0	0	0	0	0
Peeping Tom	0	0	0	0	0
Runaways	0	0	0	0	0
Trespass	0	0	0	0	0
All Other Offenses	0	0	0	0	0
<b>Total Group B Arrests</b>	<b>1</b>	<b>0</b>	<b>0</b>	<b>1</b>	<b>1</b>
<b>Total Arrests</b>	<b>2</b>	<b>0</b>	<b>0</b>	<b>2</b>	<b>2</b>



## Calls for Service:

<b>Carroll Valley Calls for Service Month</b>	<b>Total</b>
ANIMAL COMPLAINT	7
ASSIST - FIRE/EMS	12
ASSIST - OTHER POLICE	4
DOMESTIC DISTURBANCE	2
MENTAL HEALTH / WELFARE	5
MISC CALL FOR SERVICE	9
TRAFFIC COMPLAINT	18
VEHICLE STOP	11
Z FOLLOW-UP	10
SUSPICIOUS ACTIVITY	2
VEHICLE CRASH	6
DISTURBANCE/NOISE	3
ALARM	3
PTFTNA - PTHEFT NOT ACTV	1
TRESPASS	1
THEFT	7
THREATS / HARRASSMENT / STALKING	3
<b>Grand Total</b>	<b>104</b>

<b>Carroll Valley Calls for Service YTD</b>	<b>Total</b>
ALARM	3
ANIMAL COMPLAINT	7
ASSIST - FIRE/EMS	12
ASSIST - OTHER POLICE	4
DISTURBANCE/NOISE	3
DOMESTIC DISTURBANCE	2
MENTAL HEALTH / WELFARE	5
MISC CALL FOR SERVICE	10
SUSPICIOUS ACTIVITY	2
THEFT	7
THREATS / HARRASSMENT / STALKING	3
TRAFFIC COMPLAINT	18
TRESPASS	1
VEHICLE CRASH	6
VEHICLE STOP	11
Z FOLLOW-UP	10
<b>Grand Total</b>	<b>104</b>

## Traffic Enforcement:

- Officers conducted vehicle stops and handled crashes this month as listed above. Together these resulted in the following citations, faulty equipment notices, and warnings.



<b>Citation, Faulty Equipment, Warning</b>	<b>Count:</b>
1301 (Title 75) - Registration and certificate of title required	4
1501 (Title 75) - Drivers required to be licensed	1
1543 (Title 75) - Driving while operating privilege is suspended or revoked	1
1786 (Title 75) - Required financial responsibility	1
3309 (Title 75) - Driving on roadways laned for traffic	1
3323 (Title 75) - Stop signs and yield signs	1
3745 (Title 75) - Accidents involving damage to unattended vehicle or property	1
4306 (Title 75) - Use of multiple-beam road lighting equipment	1
4703 (Title 75) - Operation of vehicle without official certificate of inspection	1
5503 (Title 18) - Disorderly conduct	1
<b>Grand Total</b>	<b>13</b>

## Miscellaneous:

Calls for Service	January 2023	January 2024	YTD 2023	YTD 2024
Calls from Public	98	90	98	90
Officer initiated	25	14	25	14
Total CV Calls	123	104	123	104

		Vehicle Mileage		
		Starting	Ending	Total
20	2017 Dodge Charger Unmarked	25,690	27,600	1,910
22	2017 Dodge Charger Marked	89,450	89,713	263
49	2023 Dodge Durango Marked	4,500	6,062	1,562
50	2023 Dodge Durango Marked	335	2,887	2,552
		Total		6,287



# January 2024 Fairfield Police Report Supplement



by  
Chief Clifford Weikert  
Carroll Valley Borough Police

## Calls for Service:

This data represents all calls for service we receive from the Adams County Department of Emergency Services which accounts for most of our calls. It also includes officer-initiated calls, like traffic stops and follow ups as well as complaints received on station or by other means.

<b>Fairfield Calls for Service Month</b>	<b>Total</b>	<b>Fairfield Calls for Service YTD</b>	<b>Total</b>
ASSIST - FIRE/EMS	5	ASSIST - FIRE/EMS	5
ASSIST - OTHER POLICE	2	ASSIST - OTHER POLICE	2
DOMESTIC DISTURBANCE	1	DOMESTIC DISTURBANCE	1
DRIVING UNDER THE INFLUENCE	1	DRIVING UNDER THE INFLUENCE	1
MENTAL HEALTH / WELFARE	2	MENTAL HEALTH / WELFARE	2
MISC CALL FOR SERVICE	1	MISC CALL FOR SERVICE	1
MISSING/LOST PERSON	1	MISSING/LOST PERSON	1
TRAFFIC COMPLAINT	4	TRAFFIC COMPLAINT	4
VEHICLE CRASH	1	VEHICLE CRASH	1
VEHICLE STOP	28	VEHICLE STOP	28
<b>Grand Total</b>	<b>46</b>	<b>Grand Total</b>	<b>46</b>

## Citations

:We issued the following citations , faulty equipment, and warning cards in Fairfield Borough:

<b>Citation, Faulty Equipment, Warning</b>	<b>Count:</b>
1301 (Title 75) - Registration and certificate of title required	9
1501 (Title 75) - Drivers required to be licensed	2
3111 (Title 75) - Obedience to traffic-control devices	1
3323 (Title 75) - Stop signs and yield signs	2
3362 (Title 75) - Maximum speed limits	9
4303 (Title 75) - General lighting requirements	5
<b>Grand Total</b>	<b>28</b>



# Offense and Arrest Summary Report

Printed On: 02/08/2024

Beginning Date: 01/01/2024

Ending Date: 01/31/2024

Page 1 of 1

Agency: CARROLL VALLEY BOROUGH

Municipality: Fairfield Borough

Total Offenses 0 Clearance Rate 0  
 % change from last year -100% Last years rate 0

Total Arrests 1 Hate Crime Offenses  
 % change from last year 0 Law Officers Assaulted

Group A Crime Rate per 100,000 Population : 0.00 Summary based reporting Crime Rate per 100,000 Population : 0.00

Arrest Rate per 100,000 Population : 22.30

### Offense Reporting

Group "A"	Offenses Reported	Offenses Cleared	Offenses Reported Last Year
Murder	0	0	0
Negligent Manslaughter	0	0	0
Justifiable Homicide	0	0	0
Rape	0	0	0
Robbery	0	0	0
Aggravated Assault	0	0	0
Burglary	0	0	0
Larceny	0	0	0
Motor Vehicle Theft	0	0	0
Arson	0	0	0
Simple Assault	0	0	0
Intimidation	0	0	0
Bribery	0	0	0
Counterfeiting/Forgery	0	0	0
Vandalism	0	0	0
Drug/Narcotic Violations	0	0	0
Drug Equipment Violations	0	0	0
Embezzlement	0	0	0
Extortion/Blackmail	0	0	0
Fraud	0	0	0
Gambling	0	0	0
Kidnapping	0	0	0
Pornography	0	0	0
Prostitution	0	0	0
Sodomy	0	0	1
Sexual Assault w/Object	0	0	0
Fondling	0	0	0
Incest	0	0	0
Statutory Rape	0	0	0
Stolen Property	0	0	0
Weapons Law Violations	0	0	0
Human Trafficking, Commercial Sex Acts	0	0	0
Human Trafficking, Involuntary Servitude	0	0	0
Animal Cruelty	0	0	0
<b>Total Group "A"</b>	<b>0</b>	<b>0</b>	<b>1</b>

### Crime Against Person

0 - This year  
 1 - Last year  
 -100% - Percent Change

### Crime Against Property

0 - This year  
 0 - Last year  
 0 - Percent Change

### Crime Against Society

0 - This year  
 0 - Last year  
 0 - Percent Change

### Arrest Reporting

Group "A"	Adult	Juvenile	Unknown	Total Arrests	Arrests Reported Last Year
Murder	0	0	0	0	0
Negligent Manslaughter	0	0	0	0	0
Justifiable Homicide	0	0	0	0	0
Rape	0	0	0	0	0
Robbery	0	0	0	0	0
Aggravated Assault	0	0	0	0	0
Burglary	0	0	0	0	0
Larceny	0	0	0	0	0
Motor Vehicle Theft	0	0	0	0	0
Arson	0	0	0	0	0
Simple Assault	0	0	0	0	0
Intimidation	0	0	0	0	0
Bribery	0	0	0	0	0
Counterfeiting/Forgery	0	0	0	0	0
Vandalism	0	0	0	0	0
Drug/Narcotic Violations	0	0	0	0	0
Drug Equipment Violations	0	0	0	0	0
Embezzlement	0	0	0	0	0
Extortion/Blackmail	0	0	0	0	0
Fraud	0	0	0	0	0
Gambling	0	0	0	0	0
Kidnapping	0	0	0	0	0
Pornography	0	0	0	0	0
Prostitution	0	0	0	0	0
Sodomy	0	0	0	0	0
Sexual Assault w/Object	0	0	0	0	0
Fondling	0	0	0	0	0
Incest	0	0	0	0	0
Statutory Rape	0	0	0	0	0
Stolen Property	0	0	0	0	0
Weapons Law Violations	0	0	0	0	0
Human Trafficking, Commercial Sex Acts	0	0	0	0	0
Human Trafficking, Involuntary Servitude	0	0	0	0	0
Animal Cruelty	0	0	0	0	0
<b>Total Group A Arrests</b>	<b>0</b>	<b>0</b>	<b>0</b>	<b>0</b>	<b>0</b>
<b>Group "B" Arrests</b>					
Bad Checks	0	0	0	0	0
Curfew/Vagrancy	0	0	0	0	0
Disorderly Conduct	0	0	0	0	0
DUI	1	0	0	1	0
Drunkenness	0	0	0	0	0
Family Offenses-nonviolent	0	0	0	0	0
Liquor Law Violations	0	0	0	0	0
Peeping Tom	0	0	0	0	0
Runaways	0	0	0	0	0
Trespass	0	0	0	0	0
All Other Offenses	0	0	0	0	0
<b>Total Group B Arrests</b>	<b>1</b>	<b>0</b>	<b>0</b>	<b>1</b>	<b>0</b>
<b>Total Arrests</b>	<b>1</b>	<b>0</b>	<b>0</b>	<b>1</b>	<b>0</b>

Population : 4435

Note: Last years figures are provided for comparison purposes only.

# FIRE/EMS/EMA REPORT

---

# Fairfield Fire and EMS

Fairfield, PA

This report was generated on 1/3/2024 1:32:17 PM



## Count of Incidents by Incident Type for Incident Status for Date Range

Incident Status(s): All Incident Statuses | Sort By: IncidentType | Start Date: 01/01/2023 | End Date: 12/31/2023

INCIDENT TYPE	# INCIDENTS
100 - Fire, other	1
111 - Building fire	15
114 - Chimney or flue fire, confined to chimney or flue	2
130 - Mobile property (vehicle) fire, other	1
131 - Passenger vehicle fire	5
132 - Road freight or transport vehicle fire	1
140 - Natural vegetation fire, other	1
141 - Forest, woods or wildland fire	2
142 - Brush or brush-and-grass mixture fire	10
150 - Outside rubbish fire, other	1
200 - Overpressure rupture, explosion, overheat other	1
311 - Medical assist, assist EMS crew	69
320 - Emergency medical service, other	1
321 - EMS call, excluding vehicle accident with injury	1
322 - Motor vehicle accident with injuries	33
323 - Motor vehicle/pedestrian accident (MV Ped)	2
324 - Motor vehicle accident with no injuries.	22
400 - Hazardous condition, other	1
412 - Gas leak (natural gas or LPG)	4
413 - Oil or other combustible liquid spill	1
420 - Toxic condition, other	1
440 - Electrical wiring/equipment problem, other	2
444 - Power line down	14
462 - Aircraft standby	5
511 - Lock-out	1
542 - Animal rescue	1
550 - Public service assistance, other	2
551 - Assist police or other governmental agency	6
552 - Police matter	1
553 - Public service	3
561 - Unauthorized burning	5
571 - Cover assignment, standby, moveup	1
600 - Good intent call, other	1
611 - Dispatched & cancelled en route	16
631 - Authorized controlled burning	2
651 - Smoke scare, odor of smoke	1
733 - Smoke detector activation due to malfunction	1
734 - Heat detector activation due to malfunction	1

This report displays Incidents by Incident type for the selected Incident Status (es) and chosen date range. Nemsis 2 & 3 Incidents Included.

735 - Alarm system sounded due to malfunction	7
736 - CO detector activation due to malfunction	2
745 - Alarm system activation, no fire - unintentional	8
900 - Special type of incident, other	1
<b>Total Incidents</b>	<b>256</b>

This report displays Incidents by Incident type for the selected Incident Status (es) and chosen date range. Nemsis 2 & 3 Incidents Included.



# Fairfield Fire and EMS

Fairfield, PA

This report was generated on 1/13/2024 11:05:04 AM



## Incident Type Count per Municipality per Station for Date Range

Start Date: 01/01/2023 | End Date: 12/31/2023

INCIDENT TYPE	# INCIDENTS
<b>MUNICIPALITY: BUTLER (TOWNSHIP OF)</b>	
<b>Station 2 - Fairfield Fire &amp; EMS:</b>	
324 - Motor vehicle accident with no injuries.	1
<b># Incidents for 2 - Fairfield Fire &amp; EMS:</b>	<b>1</b>
<b># INCIDENTS FOR BUTLER (TOWNSHIP OF):</b>	<b>1</b>

<b>MUNICIPALITY: CARROLL VALLEY</b>	
<b>Station 2 - Fairfield Fire &amp; EMS:</b>	
111 - Building fire	3
114 - Chimney or flue fire, confined to chimney or flue	1
130 - Mobile property (vehicle) fire, other	1
141 - Forest, woods or wildland fire	1
200 - Overpressure rupture, explosion, overheat other	1
311 - Medical assist, assist EMS crew	20
322 - Motor vehicle accident with injuries	4
324 - Motor vehicle accident with no injuries.	5
412 - Gas leak (natural gas or LPG)	1
420 - Toxic condition, other	1
440 - Electrical wiring/equipment problem, other	2
444 - Power line down	5
542 - Animal rescue	1
550 - Public service assistance, other	2
551 - Assist police or other governmental agency	2
561 - Unauthorized burning	1
600 - Good intent call, other	1
651 - Smoke scare, odor of smoke	1
733 - Smoke detector activation due to malfunction	1
734 - Heat detector activation due to malfunction	1
735 - Alarm system sounded due to malfunction	3
736 - CO detector activation due to malfunction	1
745 - Alarm system activation, no fire - unintentional	1
<b># Incidents for 2 - Fairfield Fire &amp; EMS:</b>	<b>60</b>
<b># INCIDENTS FOR CARROLL VALLEY:</b>	<b>60</b>

Only REVIEWED incidents included.



emergencyreporting.com

Doc Id: 855

Page # 1 of 5



INCIDENT TYPE	# INCIDENTS
<b>MUNICIPALITY: CASCADE-HIGHFIELD</b>	
<b>Station 2 - Fairfield Fire &amp; EMS:</b>	
111 - Building fire	1
<b># Incidents for 2 - Fairfield Fire &amp; EMS:</b>	<b>1</b>
<b># INCIDENTS FOR CASCADE-HIGHFIELD:</b>	<b>1</b>

<b>MUNICIPALITY: CUMBERLAND (TOWNSHIP OF)</b>	
<b>Station 2 - Fairfield Fire &amp; EMS:</b>	
111 - Building fire	2
131 - Passenger vehicle fire	1
142 - Brush or brush-and-grass mixture fire	1
322 - Motor vehicle accident with injuries	3
324 - Motor vehicle accident with no injuries.	2
551 - Assist police or other governmental agency	1
611 - Dispatched & cancelled en route	5
<b># Incidents for 2 - Fairfield Fire &amp; EMS:</b>	<b>15</b>
<b># INCIDENTS FOR CUMBERLAND (TOWNSHIP OF):</b>	<b>15</b>

<b>MUNICIPALITY: EMMITSBURG</b>	
<b>Station 2 - Fairfield Fire &amp; EMS:</b>	
111 - Building fire	2
611 - Dispatched & cancelled en route	1
<b># Incidents for 2 - Fairfield Fire &amp; EMS:</b>	<b>3</b>
<b># INCIDENTS FOR EMMITSBURG:</b>	<b>3</b>

<b>MUNICIPALITY: FAIRFIELD</b>	
<b>Station 2 - Fairfield Fire &amp; EMS:</b>	
311 - Medical assist, assist EMS crew	7
321 - EMS call, excluding vehicle accident with injury	1
322 - Motor vehicle accident with injuries	1
324 - Motor vehicle accident with no injuries.	2
400 - Hazardous condition, other	1
412 - Gas leak (natural gas or LPG)	2
444 - Power line down	2
462 - Aircraft standby	5
511 - Lock-out	1
553 - Public service	3
611 - Dispatched & cancelled en route	2
631 - Authorized controlled burning	1

Only REVIEWED incidents included.



INCIDENT TYPE	# INCIDENTS
745 - Alarm system activation, no fire - unintentional	3
<b># Incidents for 2 - Fairfield Fire &amp; EMS:</b>	<b>31</b>
<b># INCIDENTS FOR FAIRFIELD:</b>	<b>31</b>

MUNICIPALITY: FRANKLIN (TOWNSHIP OF)	
<b>Station 2 - Fairfield Fire &amp; EMS:</b>	
131 - Passenger vehicle fire	2
142 - Brush or brush-and-grass mixture fire	3
322 - Motor vehicle accident with injuries	3
323 - Motor vehicle/pedestrian accident (MV Ped)	1
324 - Motor vehicle accident with no injuries.	1
444 - Power line down	2
552 - Police matter	1
611 - Dispatched & cancelled en route	4
900 - Special type of incident, other	1
<b># Incidents for 2 - Fairfield Fire &amp; EMS:</b>	<b>18</b>
<b># INCIDENTS FOR FRANKLIN (TOWNSHIP OF):</b>	<b>18</b>

MUNICIPALITY: FREDERICK (COUNTY)	
<b>Station 2 - Fairfield Fire &amp; EMS:</b>	
132 - Road freight or transport vehicle fire	1
<b># Incidents for 2 - Fairfield Fire &amp; EMS:</b>	<b>1</b>
<b># INCIDENTS FOR FREDERICK (COUNTY):</b>	<b>1</b>

MUNICIPALITY: FREEDOM (TOWNSHIP OF)	
<b>Station 2 - Fairfield Fire &amp; EMS:</b>	
111 - Building fire	2
322 - Motor vehicle accident with injuries	1
631 - Authorized controlled burning	1
<b># Incidents for 2 - Fairfield Fire &amp; EMS:</b>	<b>4</b>
<b># INCIDENTS FOR FREEDOM (TOWNSHIP OF):</b>	<b>4</b>

Only REVIEWED incidents included.



INCIDENT TYPE	# INCIDENTS
<b>MUNICIPALITY: GETTYSBURG</b>	
<b>Station 2 - Fairfield Fire &amp; EMS:</b>	
111 - Building fire	1
324 - Motor vehicle accident with no injuries.	1
<b># Incidents for 2 - Fairfield Fire &amp; EMS:</b>	<b>2</b>
<b># INCIDENTS FOR GETTYSBURG:</b>	<b>2</b>

<b>MUNICIPALITY: HAMILTONBAN (TOWNSHIP OF)</b>	
<b>Station 2 - Fairfield Fire &amp; EMS:</b>	
111 - Building fire	2
114 - Chimney or flue fire, confined to chimney or flue	1
131 - Passenger vehicle fire	1
140 - Natural vegetation fire, other	1
142 - Brush or brush-and-grass mixture fire	2
150 - Outside rubbish fire, other	1
311 - Medical assist, assist EMS crew	21
320 - Emergency medical service, other	1
322 - Motor vehicle accident with injuries	11
324 - Motor vehicle accident with no injuries.	6
444 - Power line down	1
561 - Unauthorized burning	3
611 - Dispatched & cancelled en route	1
735 - Alarm system sounded due to malfunction	3
745 - Alarm system activation, no fire - unintentional	3
<b># Incidents for 2 - Fairfield Fire &amp; EMS:</b>	<b>58</b>
<b># INCIDENTS FOR HAMILTONBAN (TOWNSHIP OF):</b>	<b>58</b>

<b>MUNICIPALITY: HIGHLAND (TOWNSHIP OF)</b>	
<b>Station 2 - Fairfield Fire &amp; EMS:</b>	
142 - Brush or brush-and-grass mixture fire	1
311 - Medical assist, assist EMS crew	9
322 - Motor vehicle accident with injuries	2
324 - Motor vehicle accident with no injuries.	1
412 - Gas leak (natural gas or LPG)	1
413 - Oil or other combustible liquid spill	1
444 - Power line down	1
551 - Assist police or other governmental agency	1
736 - CO detector activation due to malfunction	1
<b># Incidents for 2 - Fairfield Fire &amp; EMS:</b>	<b>18</b>
<b># INCIDENTS FOR HIGHLAND (TOWNSHIP OF):</b>	<b>18</b>

Only REVIEWED incidents included.



INCIDENT TYPE	# INCIDENTS
<b>MUNICIPALITY: LIBERTY (TOWNSHIP OF)</b>	
<b>Station 2 - Fairfield Fire &amp; EMS:</b>	
111 - Building fire	1
131 - Passenger vehicle fire	1
142 - Brush or brush-and-grass mixture fire	3
311 - Medical assist, assist EMS crew	11
322 - Motor vehicle accident with injuries	5
324 - Motor vehicle accident with no injuries.	3
444 - Power line down	3
551 - Assist police or other governmental agency	2
561 - Unauthorized burning	1
611 - Dispatched & cancelled en route	1
735 - Alarm system sounded due to malfunction	1
745 - Alarm system activation, no fire - unintentional	1
<b># Incidents for 2 - Fairfield Fire &amp; EMS:</b>	<b>33</b>
<b># INCIDENTS FOR LIBERTY (TOWNSHIP OF):</b>	<b>33</b>

<b>MUNICIPALITY: SABILLASVILLE</b>	
<b>Station 2 - Fairfield Fire &amp; EMS:</b>	
111 - Building fire	1
<b># Incidents for 2 - Fairfield Fire &amp; EMS:</b>	<b>1</b>
<b># INCIDENTS FOR SABILLASVILLE:</b>	<b>1</b>

<b>MUNICIPALITY: WASHINGTON (TOWNSHIP OF)</b>	
<b>Station 2 - Fairfield Fire &amp; EMS:</b>	
141 - Forest, woods or wildland fire	1
322 - Motor vehicle accident with injuries	2
323 - Motor vehicle/pedestrian accident (MV Ped)	1
571 - Cover assignment, standby, moveup	1
611 - Dispatched & cancelled en route	2
<b># Incidents for 2 - Fairfield Fire &amp; EMS:</b>	<b>7</b>
<b># INCIDENTS FOR WASHINGTON (TOWNSHIP OF):</b>	<b>7</b>

Only REVIEWED incidents included.



# Fairfield Fire and EMS

Fairfield, PA

This report was generated on 1/3/2024 1:33:45 PM



## Unfiled Losses For Date Range

Start Date: 01/01/2023 | End Date: 12/31/2023

# INCIDENTS	TOTAL PRE-INCIDENT PROP. VAL.	TOTAL PRE-INCIDENT CONT. VAL.	TOTAL PRE-INCIDENT VAL.	AVG. VAL.	TOTAL PROP. LOSS	TOTAL CONT. LOSS	TOTAL LOSSES	AVERAGE LOSS
3	\$155,000.00	\$70,000.00	\$225,000.00	\$75,000.00	\$155,000.00	\$70,000.00	\$225,000.00	\$75,000.00

INCIDENT #	DATE	TYPE	LOCATION	PRE-INCIDENT PROPERTY	PRE-INCIDENT CONTENTS	PRE-INCIDENT TOTAL	PROP. LOSS	CONT. LOSS	TOTAL
2023-37785	07/04/2023	111 - Building fire	23 Gladys Trl Carroll Valley	\$100,000.00	\$0.00	\$100,000.00	\$100,000.00	\$0.00	\$100,000.00
2023-46293	08/13/2023	111 - Building fire	701 Jacks Mountain Rd Carroll Valley	\$50,000.00	\$70,000.00	\$120,000.00	\$50,000.00	\$70,000.00	\$120,000.00
2023-55770	09/28/2023	322 - Motor vehicle accident with injuries	120 W Main St Fairfield	\$5,000.00	\$0.00	\$5,000.00	\$5,000.00	\$0.00	\$5,000.00

0 Reviewed Incidents included.



1/30/23, 6:28 AM

fire coverage percentage

Bill,

Here are the percentages of each township covered by your fire company. Please note that these are using the new fire boundaries that you completed in 2022.

Fairfield: 100%  
Carroll Valley: 87.73%  
Cumberland: less than 0.01%  
Franklin: less than 0.01%  
Freedom: 2.94%  
Hamiltonban: 56.57%  
Highland: 47.58%  
Liberty: 66.89%

calls 2023  
31  
120  
  
58  
18  
33

*Bradley Kommeth*

Adams County Dept of Emergency Services  
GIS Technician  
230 Greenamyre Ln  
Gettysburg, PA 17325  
bkommeth@adamscountypa.gov  
Office: 717-337-9824 x3021  
Fax: 717-334-1822

**\*Please note, on December 19, 2022 my email address will be changing to [bkommeth@adamscountypa.gov](mailto:bkommeth@adamscountypa.gov). Please update any information. Thank you.**

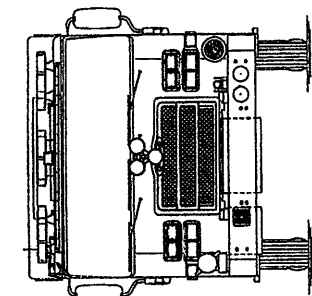

- ① INSULATED CAPACITANCE
- ② 1800 RPM
- ③ 1800 RPM
- ④ 1800 RPM

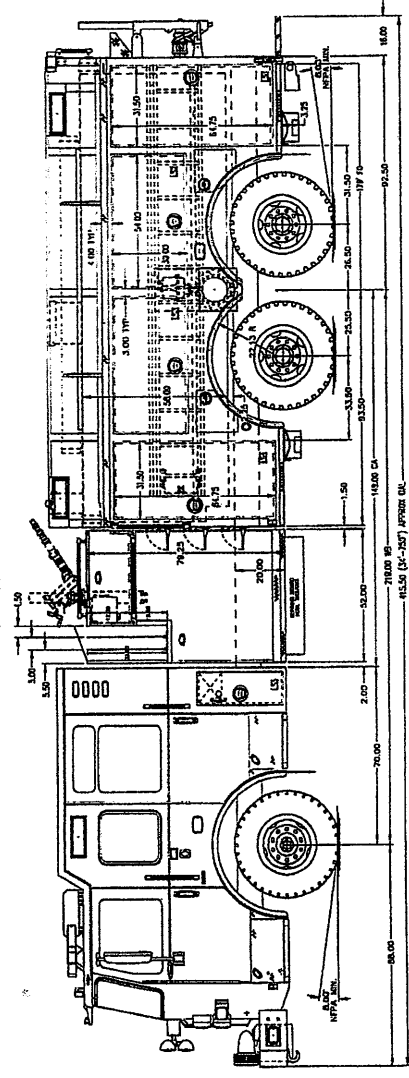
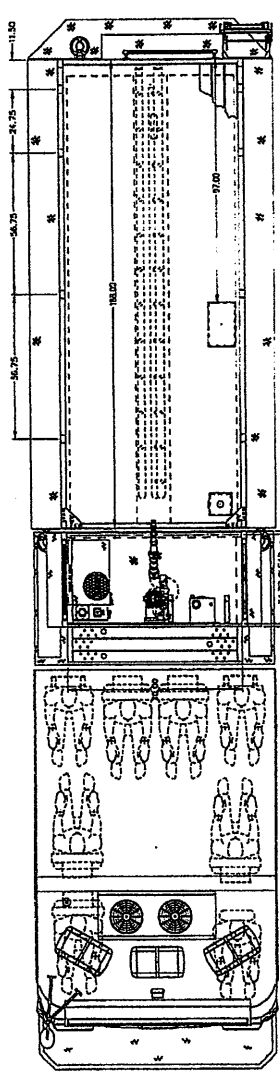
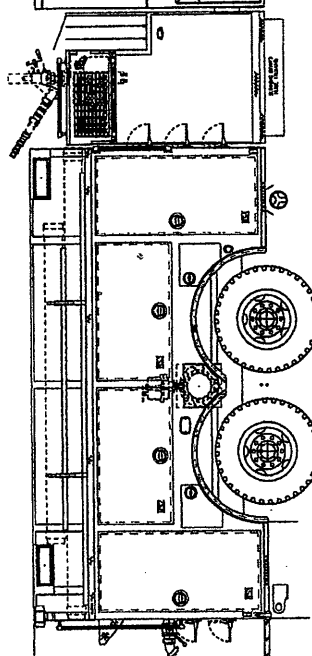
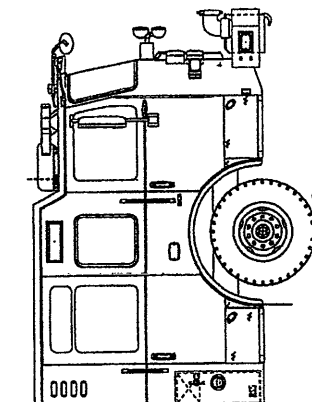
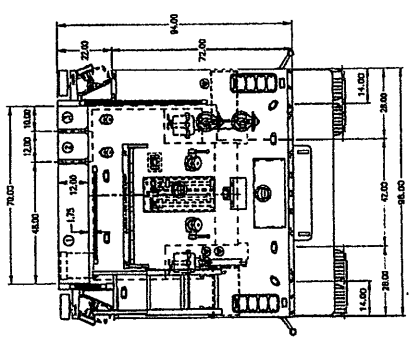
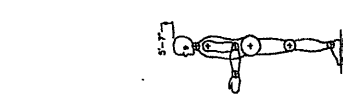

PROPOSAL		800
SCALE	DATE	
1:1	11-24	
DRAWN BY	DATE	25MARCH2023
DESIGNED BY	DATE	
N/A	N/A	
REVISED BY	DATE	
D		
SHEET NO.		1 OF 1

**Pierce** MANUFACTURING INC.  
 1500-P-2000P 1970 WATER 30 FOAM 185" FULL HEIGHT  
 FENDER (3) 3-LAYS DELUGE GENERATOR, SIDE DUMP VALVES  
 FOR FAIRFIELD FIRE & EMS  
 FAIRFIELD, PA

CAUSE	DATE	BY	NO.
PIERCE			
ENFORCER			

**ALUMINUM BODY**  
 MAXIMUM O.A.L. 420.00"  
 MAXIMUM O.A.H. 121.00"  
 SIDE ROLL AND FRONTAL IMPACT PROTECTION

NOTE  
 DIMENSIONS SHOWN ARE APPROXIMATE  
 AND ARE SUBJECT TO MINOR DEVIATIONS  
 AS MAY OCCUR OR BE NECESSARY IN  
 CONSTRUCTION.  
 MINOR DETAILS NOT SHOWN.

# Fairfield Community Fire Company Outdoor Event 2024



**TICKETS AVAILABLE 1-21-24**  
**Call 717-642-8842, EX 2**

**Fairfield Community Fire Company Outdoor Event - \$5000.00 Jackpot**  
**Saturday June 8, 2024 Outside Event - Rain or Shine**

Beginning at 12:00 PM and **every 15 minutes thereafter** we will draw a ticket for cash prizes, for a total giveaway of \$2400.00 over the course of the afternoon.

Every ticket drawn through out the afternoon will go back into the drum for the next drawing so you can possibly win multiple times throughout the day.

**At 4:00 PM we will draw a ticket for the \$5,000.00 Jackpot.**

**WINNERS DO NOT NEED TO BE PRESENT TO WIN!!!!**

**\$30.00 TICKET PER PERSON - 2 Chance To Win on every ticket**  
**MUST BE 18 YEARS OLD TO ATTEND**

**Gates Open at 10:00 AM. Lunch Will Be Served from 12:00 PM Till 2:00 PM**

Soda, Water and Adult Beverages will be available beginning at 10:30 AM until the final Jackpot Drawing.

**Small Games of Chance and Gun Jars will be available to purchase.**

**Please Feel Free To Bring Your Canopy and Lawn Chairs.**





**Fountain Dale Volunteer Department**  
1340 Old Waynesboro Road  
Fairfield, PA 17320  
717-794-2021  
*Proudly serving our community since 1946*

## **MONTHLY FIRE REPORT FOR JANUARY 2024**

Breakdown of calls by type:

Building Fire.....	4
Inside Investigation.....	1
Vehicle Accident.....	1
Medical Assist.....	4
<u>Good Intent.....</u>	<u>5</u>
<b>TOTAL</b>	<b>15</b>

Notes: 15 Calls for the month. After meeting with Fire Truck manufacturers, we have made a decision to purchase a new Pumper Tanker on a 2 door commercial chassis on a Kenworth. The price for this truck will be about \$630,000. It will be able to function both as a tanker and a pumper. I have attached a copy of the features on this truck. We will have to finance a portion of the new truck.

David Martin

Fire Chief

cc: Carroll Valley Borough  
Hamiltonban Township  
Liberty Township

## NEW APPARATUS PURCHASE FOR FOUNTAIN DALE VOLUTEER FIRE DEPARTMENT

The Fire Department voted and signed a contract to purchase a 2025 Pumper Tanker from Midwest Fire Apparatus in late December, 2023. Delivery should be about 20 to 22 months. While being a 2 person commercial truck, it will be able to function both as a tanker and an engine.

### FEATURES OF THIS APPARATUS

- 2025 Kenworth Chassis
- 565 Horsepower Cummins Diesel Engine
- Allison Automatic Transmission
- 1,500 Gallons per minute Hale Pump
- 2,500 Gallons of water
- 2,500 Gallon port-a-tank
- 3 Electric dump valves. Rear and both sides
- 5 Preconnected handlines
- 1,000 Feet of 5" hose, 400 feet of 3" and 250 feet of 2 ½ inch preconnected hand line
- Elkhart extendable deck gun
- 6,000 watt inverter with 150 feet cord reel
- Full compliment of ladders
- 3 Sections of hard sleeves
- Pike poles
- Ventilation fan
- Ventilation saw
- Hand Tools
- Various adapters
- Thermal imaging camera
- On board 3 camera system for the driver
- Rear traffic advisor light

PRICE IS \$630,000, DELIVERY IN ABOUT 20 MONTHS



# Fountain Dale Volunteer Fire Department

x

Fountain Dale, PA

This report was generated on 2/6/2024 9:49:32 PM

## Incident Type Count per Station for Date Range

Start Date: 01/01/2024 | End Date: 01/31/2024

Station: <input type="checkbox"/>	INCIDENT TYPE	# INCIDENTS
	111 - Building fire	3
	114 - Chimney or flue fire, confined to chimney or flue	1
	251 - Excessive heat, scorch burns with no ignition	1
	311 - Medical assist, assist EMS crew	3
	320 - Emergency medical service, other	1
	322 - Motor vehicle accident with injuries	1
	611 - Dispatched & cancelled en route	5
	<b># Incidents for :</b>	<b>15</b>

Only REVIEWED incidents included.



emergencyreporting.com  
Doc Id: 857

# Fountain Dale Volunteer Fire Department

x

Fairfield, PA

This report was generated on 2/6/2024 9:39:58 PM

## Incident Type and Street Name for Date Range

Incident Status: Reviewed | Start Date: 01/01/2024 | End Date: 01/31/2024

Incident Date	Address	Incident Type
01/03/2024	Monterey Lane, Blue Ridge Summit, PA 17214	Chimney or flue fire, confined to chimney or flue
01/04/2024	Furnace Road, Blue Ridge Summit, PA 17214	Dispatched & cancelled en route
01/05/2024	Military Road, Cascade-Highfield, MD 21719	Building fire
01/06/2024	Military Road, Cascade-Highfield, MD 21719	Building fire
01/06/2024	Cullen Drive, Sabillasville, MD 21780	Medical assist, assist EMS crew
01/07/2024	Naylor Road, Sabillasville, MD 21780	Emergency medical service, other
01/09/2024	Skylark Trail, Fairfield, PA 17320	Medical assist, assist EMS crew
01/12/2024	Fairfield Road, Gettysburg, PA 17325	Dispatched & cancelled en route
01/12/2024	Mount Hope Road, Fairfield, PA 17320	Building fire
01/15/2024	Monterey Lane, Washington (Township of), PA 17214	Dispatched & cancelled en route
01/16/2024	Anthony Highway, Waynesboro, PA 17268	Dispatched & cancelled en route
01/18/2024	Cove Hollow Road, Fairfield, PA 17320	Medical assist, assist EMS crew
01/21/2024	Pennersville Road, Washington (Township of), PA 17214	Excessive heat, scorch burns with no ignition
01/24/2024	Raven Rock Road, Sabillasville, MD 21780	Dispatched & cancelled en route
01/31/2024	Old Waynesboro Road, Fairfield, PA 17320	Motor vehicle accident with injuries

Lists the Incident Date, Street Name (including City, State, Zip), and Incident Type of incidents occurring within the given Date Range. Only Reviewed incidents are included.



emergencyreporting.com

# COMMITTEE REPORTS

---

---

---

**MEMORANDUM**

---

---



**TO:** BOROUGH COUNCIL; MAYOR  
**FROM:** DAVID HAZLETT, BOROUGH MANAGER  
**SUBJECT:** COMMITTEE VOLUNTEERS  
**DATE:** 2/8/2024  
**CC:** GAYLE MARTHERS

Everyone,

We have received interest from the following individuals to take part on one of our committees:

- Michael Weary (Oak Trail) is interested in the Environmental Advisory Board.
- Sharon Eklund (address unknown) is interested in any assignment.

---

---

**MEMORANDUM**

---

---



**TO:** BOROUGH COUNCIL; MAYOR  
**FROM:** DAVID HAZLETT, BOROUGH MANAGER  
**SUBJECT:** NATURE TRAIL AD HOC COMMITTEE  
**DATE:** 2/6/2024  
**CC:** GAYLE MARTHERS;

---

Everyone,

We have received interest from the following individuals to take part in the planning of the Nature Trail on the Skylark Trail Property (*Italics* indicate the person chosen for New Park Committee, **Bold** indicates the person who applied but not chosen for New Park Committee):

- |    |               |                   |
|----|---------------|-------------------|
| 1  | Aaron         | Baker             |
| 2  | <i>Jim</i>    | <i>Detwiler</i>   |
| 3  | <b>Chris</b>  | <b>Nigida</b>     |
| 4  | <b>Amanda</b> | <b>Richardson</b> |
| 5  | Bruce         | Rowland           |
| 6  | Pam           | Rowland           |
| 7  | Tim           | Skoczen           |
| 8  | John          | Jacklitsch        |
| 9  | Rosia         | Jacklitsch        |
| 10 | Susan         | Langton           |
| 11 | <i>Rob</i>    | <i>Meier</i>      |
| 12 | <i>Jesse</i>  | <i>Phillips</i>   |

I recommend the people listed above, 1-7, to be selected for this project.



Planning Meeting 2/5/2024

- Approved December minutes
- Open to the public - no public comments
- New Business
- Old Business
  - Long-Term Rentals - Rules/Regulations
    - Focus of the meeting, a lot of good discussion
    - Work-in-progress, nothing to recommend at this time
  - Chapter 22 Review
    - Work-in-progress, nothing to recommend at this time
- Adjourned

Respectfully Submitted,  
Michael Wight, Chair

# ADMINISTRATIVE BUSINESS

---

**BOROUGH OF CARROLL VALLEY SUMMARY FINANCIAL REPORT: 1 thru 31 JANUARY 2024**

ACCOUNT	GENERAL FUND	SPECIAL EVENT	SANITARY SEWER	SINKING FUND	CAPITAL RESERVE	HIGHWAY AID (LF)	TOTAL FUNDS
START OF PERIOD							
CHECKING ACCOUNT	\$59,637.95	\$0.00	\$0.00	\$145.50	\$76,765.61	\$0.00	\$136,549.06
INVESTMENTS	\$2,018,507.60	\$0.00	\$219,188.89	\$0.00	\$0.00	\$871,941.47	\$3,109,637.96
PETTY CASH	\$425.00	\$0.00	\$25.00	\$0.00	\$0.00	\$0.00	\$450.00
DUE FROM OTHER FUNDS	\$28,431.46	\$13,072.44	\$776,917.61	\$0.00	\$928,288.13	\$0.00	\$1,746,709.64
DUE TO OTHER FUNDS	\$1,202,060.58	\$11,566.05	\$415,282.47	\$0.00	\$116,960.16	\$0.00	\$1,745,869.26
LIABILITIES	\$26,116.15	\$0.00	\$0.00	\$0.00	\$0.00	\$0.00	\$26,116.15
NET BALANCE	\$878,825.28	\$1,506.39	\$580,849.03	\$145.50	\$888,093.58	\$871,941.47	\$3,221,361.25
TRANSACTIONS FOR PERIOD							
ADJUSTMENTS (SEE NOTE)							
ACTUAL REVENUES (+)	\$72,973.53	\$3,375.00	\$73,882.58	\$0.00	\$4,986.50	\$3,839.66	\$159,057.27
ACTUAL EXPENDITURES (-)	\$267,892.64	\$1,160.00	\$60,254.13	\$0.00	\$37,323.08	\$0.00	\$366,629.85
ENCUMBERED FUNDS (-)							\$0.00
NET TRANSACTION BALANCE	(\$194,919.11)	\$2,215.00	\$13,628.45	\$0.00	(\$32,336.58)	\$3,839.66	(\$207,572.58)
END OF PERIOD							
CHECKING ACCOUNT	\$62,647.16	\$0.00	\$0.00	\$145.50	\$77,037.49	\$0.00	\$139,830.15
INVESTMENTS	\$1,803,133.16	\$0.00	\$220,154.07	\$0.00	\$0.00	\$875,781.13	\$2,899,068.36
PETTY CASH	\$425.00	\$0.00	\$25.00	\$0.00	\$0.00	\$0.00	\$450.00
DUE FROM OTHER FUNDS	\$99,054.01	\$15,996.01	\$827,923.12	\$0.00	\$927,251.41	\$0.00	\$1,870,224.55
DUE TO OTHER FUNDS	\$1,254,952.94	\$12,274.62	\$453,605.46	\$0.00	\$148,531.90	\$0.00	\$1,869,364.92
LIABILITIES	\$16,077.46	\$0.00	\$0.00	\$0.00	\$0.00	\$0.00	\$16,077.46
NET BALANCE	\$694,228.93	\$3,721.39	\$594,496.73	\$145.50	\$855,757.00	\$875,781.13	\$3,024,130.68

Range of Checking Accts: First to Last      Range of Check Dates: 01/01/24 to 01/31/24  
Report Type: All Checks      Report Format: Detail      Check Type: Computer: Y Manual: Y Dir Deposit: Y

Check #	Check Date	Vendor	Amount Paid	Charge Account	Account Type	Reconciled/Void Contract	Ref Num
PO #	Item	Description					Ref Seq Acct
GENERAL FUND	GENERAL FUND						
40558	01/05/24	ACTCO005 AC&T CO, INC.					40
v4-00041	1	Fuel & Diesel Fuel: Dec 2023	30.72	01-413-231	Expenditure		57 1
				FUEL			
v4-00041	2	Fuel & Diesel Fuel: Dec 2023	25.60	01-454-231	Expenditure		58 1
				FUEL			
v4-00041	3	Fuel & Diesel Fuel: Dec 2023	665.90	01-410-231	Expenditure		59 1
				FUEL			
v4-00041	4	Fuel & Diesel Fuel: Dec 2023	1,121.43	01-430-231	Expenditure		60 1
				FUEL			
v4-00041	5	Fuel & Diesel Fuel: Dec 2023	569.30	01-430-363	Expenditure		61 1
				Propane Gas			
			<u>2,412.95</u>				
40559	01/05/24	AMERI005 AMERICAN UNITED LIFE INS					40
v4-00027	1	Life & Disability Premium: Jan	249.59	01-401-197	Expenditure		40 1
				LIFE/DISABILITY INSURANCE			
v4-00027	2	Life & Disability Premium: Jan	120.74	01-410-197	Expenditure		41 1
				LIFE/DISABILITY INSURANCE			
v4-00027	3	Life & Disability Premium: Jan	303.55	01-430-197	Expenditure		42 1
				LIFE/DISABILITY INSURANCE			
v4-00027	4	Life & Disability Premium: Jan	59.03	08-429-197	Expenditure		43 1
				LIFE/DISABILITY INSURANCE			
			<u>732.91</u>				
40560	01/05/24	ASSOC005 ASSOC. OF MAYORS OF BOROUGHS O					40
v4-00014	1	2024 Membership	60.00	01-400-420	Expenditure		22 1
				DUES/SUBSCRIPTONS/MEMBERSHIPS			
40561	01/05/24	ATTMO005 AT&T MOBILITY					40
v4-00020	1	wireless svc: 11/19/23-12/18	43.16	01-430-321	Expenditure		29 1
				COMMUNICATIONS			
v4-00020	2	wireless svc: 11/19/23-12/18	48.22	01-401-321	Expenditure		30 1
				TELEPHONE SER & INSTALN			
v4-00021	1	GeoTabs: 11/19/23-12/18/23	96.25	01-410-331	Expenditure		31 1
				Travel GPS			
v4-00021	2	GeoTabs: 11/19/23-12/18/23	19.25	01-413-331	Expenditure		32 1
				Travel GPS			
v4-00021	3	GeoTabs: 11/19/23-12/18/23	19.25	08-429-331	Expenditure		33 1
				Travel GPS			
v4-00021	4	GeoTabs: 11/19/23-12/18/23	231.00	01-430-331	Expenditure		34 1
				Travel GPS			
			<u>457.13</u>				
40562	01/05/24	BRADA005 BRAD A. SANDERS					40
v4-00025	1	2023 Clothing Allowance	100.00	01-430-238	Expenditure		38 1
				CLOTHING ALLOWANCE			

Check #	Check Date	Vendor	Amount Paid	Charge Account	Account Type	Reconciled/Void Contract	Ref Num
PO #	Item	Description					Ref Seq Acct
GENERAL FUND	GENERAL FUND	Continued					
40563	01/05/24	COMMO005 COMMONWEALTH OF PENNSYLVANIA					40
v4-00010	1	NPDES Permit	1,000.00	08-429-420	Expenditure		10 1
				DUES, SUBSCRIP, MEMBERSHIPS			
40564	01/05/24	EHRLI005 EHRLICH					40
v4-00026	1	Pest Control Service	219.53	01-409-374	Expenditure		39 1
				MAINT SERVICES-EQUIPMENT			
40565	01/05/24	FIRED FIRED UP! ENTERTAINMENT					40
v4-00024	1	Daddy Daughter Dance DJ	350.00	04-496-200	Expenditure		37 1
				Daddy/Daughter Dance			
40566	01/05/24	GETTY005 GETTYSBURG TIMES					40
v4-00028	1	Legal Ad: 2024 Budget Notice	74.03	01-401-341	Expenditure		44 1
				ADVERTISING-GENERAL			
v4-00029	1	Legal Ad: 2024 Tax Rate	451.04	01-401-341	Expenditure		45 1
				ADVERTISING-GENERAL			
v4-00030	1	Legal Ad: Civil Service	40.63	01-401-341	Expenditure		46 1
				ADVERTISING-GENERAL			
v4-00031	1	Legal Ad: 2024 Budget & Tax Ra	58.33	01-401-341	Expenditure		47 1
				ADVERTISING-GENERAL			
v4-00032	1	Legal Ad: ZHB Fifty Properties	143.29	01-401-341	Expenditure		48 1
				ADVERTISING-GENERAL			
			<u>767.32</u>				
40567	01/05/24	GOVER005 GOVERNMENT MANAGEMENT SERVICES					40
v4-00001	1	Retainer for the month of Jan	3,000.00	01-404-131	Expenditure		1 1
				Professional Services - Grants			
40568	01/05/24	KETTE005 KETTERMAN ELECTRICAL SERVICE					40
v4-00004	1	Check breaker tripping	142.50	08-429-375	Expenditure		4 1
				OUT-SOURCE REPAIR - EQUIPMENT			
40569	01/05/24	KEYST005 KEYSTONE MUNICIPAL INSURANCE					40
v4-00013	1	1 of 4 KMIT WC 2024	6,029.00	01-486-151	Expenditure		20 1
				WORKERS COMP-CUR YEAR			
v4-00013	2	1 of 4 KMIT WC 2024	250.00	01-486-151	Expenditure		21 1
				WORKERS COMP-CUR YEAR			
			<u>6,279.00</u>				
40570	01/05/24	KILME005 KILMER INSURANCE AGENCY					40
v4-00034	1	2024-2025 Commercial Auto 1 of	9,118.00	01-486-352	Expenditure		50 1
				PROPERTY INS/COMPUTER EQUIP			
v4-00035	1	2024-2025 Commercial Package	11,394.00	01-486-352	Expenditure		51 1
				PROPERTY INS/COMPUTER EQUIP			
v4-00036	1	2024-2025 Professional Liabili	4,296.00	01-486-352	Expenditure		52 1
				PROPERTY INS/COMPUTER EQUIP			
v4-00037	1	2024-2025 Commercial Umbrella	4,547.00	01-486-352	Expenditure		53 1
				PROPERTY INS/COMPUTER EQUIP			
			<u>29,355.00</u>				

Check #	Check Date	Vendor	Amount Paid	Charge Account	Account Type	Reconciled/Void Contract	Ref Num	Ref Seq	Acct
PO #	Item	Description							
GENERAL FUND									
40571	01/05/24	KPITE005 KPI TECHNOLOGY							40
v4-00038	1	SEO Services	5,692.83	01-413-440	Expenditure		54		1
				CONTRACTED SERVICES-SEO					
40572	01/05/24	LABOR005 LABORATORY, ANALYTICAL & BIOLO							40
v4-00005	1	STP: Testing December 2023	264.00	08-429-316	Expenditure		5		1
				CONTRACT.SERVCS-LABORATORY					
40573	01/05/24	LOWES005 LOWES IN-STORE ACCOUNT							40
v4-00023	1	Split Rail Fencing	648.33	30-454-651	Expenditure		36		1
				CAPITAL CONSTRUCTION					
40574	01/05/24	METED005 MET-ED							40
v4-00022	1	Street Light: December 2023	85.55	01-434-361	Expenditure		35		1
				ELECTRICITY					
40575	01/05/24	PAMUN010 PA MUNICIPAL HEALTH INSURANCE							40
v4-00011	1	January 2024: Major Medical, D	9,991.78	01-401-196	Expenditure		11		1
				MAJOR MEDICAL INSURANCE					
v4-00011	2	January 2024: Major Medical, D	247.16	01-401-198	Expenditure		12		1
				DENTAL/VISION INSURANCE					
v4-00011	3	January 2024: Major Medical, D	8,329.30	01-410-196	Expenditure		13		1
				MAJOR MEDICAL INSURANCE					
v4-00011	4	January 2024: Major Medical, D	212.38	01-410-198	Expenditure		14		1
				DENTAL/VISION INSURANCE					
v4-00011	5	January 2024: Major Medical, D	14,156.43	01-430-196	Expenditure		15		1
				MAJOR MEDICAL INSURANCE					
v4-00011	6	January 2024: Major Medical, D	353.35	01-430-198	Expenditure		16		1
				DENTAL/VISION INSURANCE					
v4-00011	7	January 2024: Major Medical, D	1,662.48	08-429-196	Expenditure		17		1
				MAJOR MEDICAL INSURANCE					
v4-00011	8	January 2024: Major Medical, D	106.19	08-429-198	Expenditure		18		1
				DENTAL/VISION INSURANCE					
			<u>35,059.07</u>						
40576	01/05/24	PARUR005 PA RURAL WATER ASSOC.							40
v4-00003	1	PRWA Training Seminar	135.00	08-429-460	Expenditure		3		1
				CONTINUING EDUCATION/CONF.					
40577	01/05/24	PASTA010 PA STATE MAYORS ASSOCIATION							40
v4-00012	1	2024 Dues	70.00	01-400-420	Expenditure		19		1
				DUES/SUBSCRIPTONS/MEMBERSHIPS					
40578	01/05/24	PSAB0005 PSAB							40
v4-00006	1	Extended Listing in Membership	40.00	01-400-420	Expenditure		6		1
				DUES/SUBSCRIPTONS/MEMBERSHIPS					
v4-00007	1	2024 Borough News Subscription	80.00	01-400-420	Expenditure		7		1
				DUES/SUBSCRIPTONS/MEMBERSHIPS					
v4-00008	1	CDL Renewal: 1/1/24-12/31/24	75.00	01-430-302	Expenditure		8		1
				COMMERCIAL LICENSES					
v4-00015	1	2024 Borough Councils Assn. Du	30.00	01-400-420	Expenditure		23		1
				DUES/SUBSCRIPTONS/MEMBERSHIPS					

Check #	Check Date	Vendor	Amount Paid	Charge Account	Account Type	Reconciled/Void Contract	Ref Num	Ref Seq	Acct
PO #	Item	Description							
GENERAL FUND	GENERAL FUND	Continued							
40578	PSAB	Continued							
v4-00016	1	2024 Borough Membership Dues	548.00	01-400-420	Expenditure		24	1	
				DUES/SUBSCRIPTONS/MEMBERSHIPS					
v4-00017	1	2024 PSAB Plus Training Subscr	450.00	01-400-460	Expenditure		25	1	
				CONTINUING EDUCATION/CONF.					
			<u>1,223.00</u>						
40579	01/05/24	SALZM005 SALZMANN HUGHES, P.C.						40	
v4-00039	1	WWTP Expansion: PennVest Serv	34,325.00	08-429-602	Expenditure		55	1	
				CAPITAL CONST: Project #2					
v4-00040	1	Representation as Borough Soli	5,012.20	01-404-130	Expenditure		56	1	
				SOLICITOR FEES					
			<u>39,337.20</u>						
40580	01/05/24	STACY005 STACY L. KRIETZ						40	
v4-00033	1	Office Cleaning: 12/17/23-12/3	316.00	01-409-450	Expenditure		49	1	
				CONTRACTED SERS-CUSTODIAN					
40581	01/05/24	TMOBI005 T-MOBILE						40	
v4-00018	1	wireless svc: 11/22/23-12/21/2	69.86	01-401-321	Expenditure		26	1	
				TELEPHONE SER & INSTALN					
v4-00018	2	wireless svc: 11/22/23-12/21/2	69.86	08-429-321	Expenditure		27	1	
				TELEPHONE SRVCS & INSTALLATN					
v4-00019	1	PL: Connection Card Data Plan	145.60	01-410-321	Expenditure		28	1	
				COMMUNICATIONS					
			<u>285.32</u>						
40582	01/05/24	TREYS005 TREYSTA TECHNOLOGY MANAGEMENT						40	
v4-00009	1	IT Support: January 2024	1,439.20	01-407-321	Expenditure		9	1	
				INTERNET/WEB SITE CHARGES					
40583	01/05/24	WINTE005 WINTER ENGINE-GENERATOR SERVIC						40	
v4-00002	1	STP: Generator Repair	372.24	08-429-375	Expenditure		2	1	
				OUT-SOURCE REPAIR - EQUIPMENT					
40584	01/08/24	THOMP005 THOMPSON'S CUSTOM WELDING						41	
v3-00688	1	Fireplace Screen for Cortner	275.00	30-454-651	Expenditure		1	1	
				CAPITAL CONSTRUCTION					
40585	01/17/24	108EM005 10-8 EMERGENCY VEHICLE SERVICE						42	
v4-00049	1	Installation of Radios & Anten	33,947.54	30-410-740	Expenditure		8	1	
				CAP PURCHASES-MAJOR EQUIP					
40586	01/17/24	ADAMS005 ADAMS COUNTY AUTO SUPPLY, INC.						42	
v4-00046	1	EQMS11: Battery	125.37	01-430-251	Expenditure		5	1	
				EQUIP PARTS - PERIODIC REPLAC					
40587	01/17/24	ADAMS020 ADAMS ELECTRIC COOPERATIVE, IN						42	
v4-00058	1	STP: Sanders Rd. Pump Station	2,144.54	08-429-361	Expenditure		24	1	
				UTILITY SERVICE-ELECTRICITY					
v4-00059	1	STP: Country Club Trl: Pump	146.26	08-429-361	Expenditure		25	1	
				UTILITY SERVICE-ELECTRICITY					

Check #	Check Date	Vendor	Amount Paid	Charge Account	Account Type	Reconciled/Void Contract	Ref Num	Ref Seq	Num Acct
PO #	Item	Description							
GENERAL FUND	GENERAL FUND	Continued							
40587	ADAMS	ELECTRIC COOPERATIVE, IN	Continued						
v4-00060	1	Boro Office: December 2023	1,362.70	01-409-361	Expenditure		26	1	
				ELECTRICITY/HEAT					
			<u>3,653.50</u>						
40588	01/17/24	BARRY005 BARRYS LOCK & KEY SERVICE						42	
v4-00051	1	Duplicate Keys for Office	55.00	01-409-373	Expenditure		10	1	
				REPAIRS/MAIN SER-BLDGS/GRNDS					
40589	01/17/24	CIVIC005 CIVIC PLUS						42	
v4-00067	1	2024 Annual Renewal Fee	3,368.75	01-407-321	Expenditure		33	1	
				INTERNET/WEB SITE CHARGES					
40590	01/17/24	COMMU005 COMMUNITY MEDIA OF SOUTH CENT						42	
v4-00050	1	CVB Council Meeting: Dec 2023	220.00	01-400-330	Expenditure		9	1	
				Community Media Contract					
40591	01/17/24	FAIRF015 FAIRFIELD MUNICIPAL AUTHORITY						42	
v4-00072	1	4th Qtr 2023: Hydrant Fee	25.00	01-409-365	Expenditure		38	1	
				WATER					
40592	01/17/24	GETTY005 GETTYSBURG TIMES						42	
v4-00044	1	Legal Ad: ZHB Meeting	281.58	01-401-341	Expenditure		3	1	
				ADVERTISING-GENERAL					
v4-00045	1	Legal Ad: 2024 Meeting Schedul	145.06	01-401-341	Expenditure		4	1	
				ADVERTISING-GENERAL					
v4-00053	1	Legal Ad: Meeting Notice Counc	118.74	01-401-341	Expenditure		12	1	
				ADVERTISING-GENERAL					
			<u>545.38</u>						
40593	01/17/24	KELLE005 KELLER ENGINEERS, INC.						42	
v4-00073	1	Phase 2: WWTP Expansion	2,909.19	08-429-602	Expenditure		39	1	
				CAPITAL CONST: Project #2					
40594	01/17/24	KPITE005 KPI TECHNOLOGY						42	
v4-00056	1	SEO Services	2,936.70	01-413-440	Expenditure		22	1	
				CONTRACTED SERVICES-SEO					
v4-00057	1	Lake May: Dam Inspection	1,764.40	01-454-258	Expenditure		23	1	
				LAKE/DAM PREVENTATIVE MAINT					
			<u>4,701.10</u>						
40595	01/17/24	PAMUN005 PA MUNICIPAL RETIREMENT SYSTEM						42	
v4-00069	1	4th Qtr 2023: Non-Uniform	4,630.66	01-225-000	G/L		35	1	
				PENSION- EMPLOYEE CONTRIBUTION					
v4-00070	1	4th Qtr 2023: Police Pension	1,819.43	01-225-000	G/L		36	1	
				PENSION- EMPLOYEE CONTRIBUTION					
			<u>6,450.09</u>						
40596	01/17/24	PAMUN010 PA MUNICIPAL HEALTH INSURANCE						42	
v4-00054	1	February 2024: Major Medical,	9,991.78	01-401-196	Expenditure		13	1	
				MAJOR MEDICAL INSURANCE					



Check #	Check Date	Vendor	Amount Paid	Charge Account	Account Type	Reconciled/Void Contract	Ref Num	Ref Seq	Acct
PO #	Item	Description							
GENERAL FUND GENERAL FUND Continued									
40596	PA MUNICIPAL HEALTH INSURANCE	Continued							
V4-00054	2	February 2024: Major Medical,	247.16	01-401-198	Expenditure		14	1	
				DENTAL/VISION INSURANCE					
V4-00054	3	February 2024: Major Medical,	8,329.30	01-410-196	Expenditure		15	1	
				MAJOR MEDICAL INSURANCE					
V4-00054	4	February 2024: Major Medical,	212.38	01-410-198	Expenditure		16	1	
				DENTAL/VISION INSURANCE					
V4-00054	5	February 2024: Major Medical,	14,156.43	01-430-196	Expenditure		17	1	
				MAJOR MEDICAL INSURANCE					
V4-00054	6	February 2024: Major Medical,	353.35	01-430-198	Expenditure		18	1	
				DENTAL/VISION INSURANCE					
V4-00054	7	February 2024: Major Medical,	1,662.48	08-429-196	Expenditure		19	1	
				MAJOR MEDICAL INSURANCE					
V4-00054	8	February 2024: Major Medical,	106.19	08-429-198	Expenditure		20	1	
				DENTAL/VISION INSURANCE					
			<u>35,059.07</u>						
40597	01/17/24	PAUCF005 PA UC FUND						42	
V4-00074	1	2023 4th Qtr UC Pmt	148.87	01-220-000	G/L		40	1	
				PA U.C. WITHHELD & MATCH					
40598	01/17/24	PENNS005 PENNSYLVANIA CHIEFS OF POLICE						42	
V4-00042	1	Entry-Level Police Exams	114.50	01-410-303	Expenditure		1	1	
				TESTING SERVICES					
40599	01/17/24	PENNS015 PENNSYLVANIA ONE CALL SYSTEM,						42	
V4-00052	1	December 2023: Activity Fee	5.46	08-429-420	Expenditure		11	1	
				DUES, SUBSCRIP, MEMBERSHIPS					
40600	01/17/24	PSABU005 PSAB U/C PLAN						42	
V4-00075	1	4th Qtr 2023 Payment	219.79	01-220-000	G/L		41	1	
				PA U.C. WITHHELD & MATCH					
40601	01/17/24	RABOL005 RABOLDS SERVICES						42	
V4-00047	1	Installation of Adapters	360.00	30-410-740	Expenditure		6	1	
				CAP PURCHASES-MAJOR EQUIP					
V4-00048	1	January 2024 Calibrations	129.00	01-410-450	Expenditure		7	1	
				CONTRACTED SERVICES - EQUIPMEN					
			<u>489.00</u>						
40602	01/17/24	SHEAL005 SHEALERS SEPTIC SERVICE						42	
V4-00068	1	HT: December 2023	4,138.00	08-464-450	Expenditure		34	1	
				HT CONTRACTOR-CUR YR					
40603	01/17/24	STACY005 STACY L. KRIETZ						42	
V4-00043	1	Office Cleaning: 12/31/23-1/13	316.00	01-409-450	Expenditure		2	1	
				CONTRACTED SERS-CUSTODIAN					
40604	01/17/24	THEY005 THE YORK WATER COMPANY						42	
V4-00065	1	Water: svc 11/20/23-12/21/23	81.03	01-409-365	Expenditure		31	1	
				WATER					

Check #	Check Date	Vendor	Amount Paid	Charge Account	Account Type	Reconciled/Void Contract	Ref Num
PO #	Item	Description					Ref Seq Acct
GENERAL FUND	GENERAL FUND	Continued					
40605	01/17/24	TOSHI005 TOSHIBA FINANCIAL SERVICES					42
v4-00055	1	January 2024: Copier Lease	374.25	01-401-375	Expenditure		21 1
				EQUIPMENT LEASE			
40606	01/17/24	TOSHI010 TOSHIBA AMERICA BUSINESS SOLUT					42
v4-00066	1	Extra Copies	5.67	01-401-375	Expenditure		32 1
				EQUIPMENT LEASE			
40607	01/17/24	WESTP005 WEST PENN POWER					42
v4-00061	1	14 Ranch Trl: December 2023	456.84	01-430-361	Expenditure		27 1
				ELECTRICITY			
v4-00062	1	14 Ranch Trl: Barn: Dec 2023	107.63	01-430-361	Expenditure		28 1
				ELECTRICITY			
v4-00063	1	Ranch Pavilion: December 2023	129.27	01-454-361	Expenditure		29 1
				UTILITY SERVICE-ELECTRICITY			
v4-00064	1	Street Lights	2,391.64	01-434-361	Expenditure		30 1
				ELECTRICITY			
			<u>3,085.38</u>				
40608	01/17/24	YORKA005 YORK/ADAMS TAX BUREAU					42
v4-00071	1	4th Qtr 2023: Local Tax withhe	3,290.51	01-212-000	G/L		37 1
				EARNED INCOME TAXES WITHHELD			
40609	01/31/24	ACTCO005 AC&T CO, INC.					43
v4-00088	1	MS: Propane	561.51	01-430-363	Expenditure		20 1
				Propane Gas			
40610	01/31/24	ADAMS020 ADAMS ELECTRIC COOPERATIVE, IN					43
v4-00092	1	Trout Run Trl: December 2023	45.52	01-454-361	Expenditure		24 1
				UTILITY SERVICE-ELECTRICITY			
v4-00093	1	Jacks Mtn Bridge: December 202	45.68	01-433-374	Expenditure		25 1
				HIGHWAY SERVICES/SIGNALS			
v4-00094	1	Street Lights	1,682.50	01-434-361	Expenditure		26 1
				ELECTRICITY			
v4-00095	1	Pavilion: December 2023	226.95	01-454-361	Expenditure		27 1
				UTILITY SERVICE-ELECTRICITY			
v4-00096	1	Ski Run Trl: December 2023	43.53	01-454-361	Expenditure		28 1
				UTILITY SERVICE-ELECTRICITY			
v4-00097	1	MS Bldg: December 2023	163.90	01-430-361	Expenditure		29 1
				ELECTRICITY			
			<u>2,208.08</u>				
40611	01/31/24	ADAMS035 ADAMS COUNTY COUNCIL OF GOVT					43
v4-00084	1	COG Dues for 2024	100.00	01-400-420	Expenditure		13 1
				DUES/SUBSCRIPTONS/MEMBERSHIPS			
40612	01/31/24	ADVEN005 ADVENTURE IN FUN, LLC					43
v4-00083	1	Daddy Daughter Dance: Glitter	810.00	04-496-200	Expenditure		12 1
				Daddy/Daughter Dance			

Check #	Check Date	Vendor	Amount Paid	Charge Account	Account Type	Reconciled/Void Contract	Ref Num
PO #	Item	Description					Ref Seq Acct
GENERAL FUND	GENERAL FUND	Continued					
40613	01/31/24	AMERI005 AMERICAN UNITED LIFE INS					43
v4-00085	1	Life & Disability Premium: Feb	249.59	01-401-197	Expenditure		14 1
				LIFE/DISABILITY INSURANCE			
v4-00085	2	Life & Disability Premium: Feb	31.23	01-410-197	Expenditure		15 1
				LIFE/DISABILITY INSURANCE			
v4-00085	3	Life & Disability Premium: Feb	303.55	01-430-197	Expenditure		16 1
				LIFE/DISABILITY INSURANCE			
v4-00085	4	Life & Disability Premium: Feb	59.03	08-429-197	Expenditure		17 1
				LIFE/DISABILITY INSURANCE			
			<u>643.40</u>				
40614	01/31/24	ATTMO005 AT&T MOBILITY					43
v4-00077	1	wireless Svc: 12/19/23-1/18/24	43.17	01-430-321	Expenditure		2 1
				COMMUNICATIONS			
v4-00077	2	wireless Svc: 12/19/23-1/18/24	48.22	01-401-321	Expenditure		3 1
				TELEPHONE SER & INSTALN			
v4-00078	1	GeoTabs: 12/19/23-1/18/24	96.25	01-410-331	Expenditure		4 1
				Travel GPS			
v4-00078	2	GeoTabs: 12/19/23-1/18/24	19.25	01-413-331	Expenditure		5 1
				Travel GPS			
v4-00078	3	GeoTabs: 12/19/23-1/18/24	19.25	08-429-331	Expenditure		6 1
				Travel GPS			
v4-00078	4	GeoTabs: 12/19/23-1/18/24	231.00	01-430-331	Expenditure		7 1
				Travel GPS			
			<u>457.14</u>				
40615	01/31/24	CORRI005 CORRIE L. ONDRIZEK					43
v4-00087	1	ZHB: Fifty Properties, LLC	125.00	01-414-300	Expenditure		19 1
				OTHER SERVICES AND CHARGES			
40616	01/31/24	GETTY005 GETTYSBURG TIMES		(Void Reason: Duplicate Payment)		02/08/24 VOID	43
v4-00086	1	Legal Ad: Reschedule Council	118.74	01-401-341	Expenditure		18 1
				ADVERTISING-GENERAL			
40617	01/31/24	GUERN005 GUERNSEY OFFICE PRODUCTS					43
v4-00076	1	MS: Ink Cartridge	35.51	01-430-213	Expenditure		1 1
				COMPUTER SUPPLIES			
40618	01/31/24	KILME005 KILMER INSURANCE AGENCY					43
v4-00089	1	2024-2025 Pollution Policy	2,645.00	01-486-352	Expenditure		21 1
				PROPERTY INS/COMPUTER EQUIP			
40619	01/31/24	LOWES005 LOWES IN-STORE ACCOUNT					43
v4-00101	1	Repair to Clarifier	110.38	08-429-372	Expenditure		33 1
				MAINT SERVICES-SEWER SYSTEM			
40620	01/31/24	MARTI005 MARTIN TRUCK SERVICE					43
v4-00082	1	MS12: Oil	96.56	01-430-256	Expenditure		11 1
				SHOP SUPPLIES			

Check #	Check Date	Vendor	Amount Paid	Charge Account	Account Type	Reconciled/Void Contract	Ref Num
PO #	Item	Description					Ref Seq Acct
GENERAL FUND			Continued				
40621	01/31/24	MARYL005 MARYLAND BIOCHEMICAL COMPANY					43
v4-00098	1	Bacteria for Wastewater Treatm	934.87	08-429-222	Expenditure		30 1
				OPERATING SUPPLIES-CHEMICALS			
40622	01/31/24	METED005 MET-ED					43
v4-00079	1	Street Light: January 2024	87.32	01-434-361	Expenditure		8 1
				ELECTRICITY			
40623	01/31/24	MGLPR005 MGL PRINTING SOLUTIONS					43
v4-00099	1	w-2 Paper and Envelopes	87.00	01-401-220	Expenditure		31 1
				COPIER SUPPLIES			
40624	01/31/24	PATUR005 PA TURNPIKE TOLL BY PLATE					43
v4-00080	1	Turnpike Toll	17.20	01-410-460	Expenditure		9 1
				CONTINUING EDUCATION/CONF.			
40625	01/31/24	SELEC005 SELECTIVE INSURANCE					43
v4-00090	1	Flood Insurance: 4/11/24-4/10/	1,168.00	01-486-355	Expenditure		22 1
				FLOOD			
40626	01/31/24	STACY005 STACY L. KRIETZ					43
v4-00081	1	Office Cleaning: 1/14/24-1/27/	316.00	01-409-450	Expenditure		10 1
				CONTRACTED SERS-CUSTODIAN			
40627	01/31/24	TMOBI005 T-MOBILE					43
v4-00102	1	Wirless Svc: 12/22/23-1/21/24	69.87	08-429-321	Expenditure		34 1
				TELEPHONE SRVCS & INSTALLATN			
v4-00102	2	Wirless Svc: 12/22/23-1/21/24	69.87	01-401-321	Expenditure		35 1
				TELEPHONE SER & INSTALN			
v4-00103	1	PL: Connection Card Data Plan	145.60	01-410-321	Expenditure		36 1
				COMMUNICATIONS			
			<u>285.34</u>				
40628	01/31/24	TREYS005 TREYSTA TECHNOLOGY MANAGEMENT					43
v4-00091	1	IT Support: February 2024	1,424.20	01-407-321	Expenditure		23 1
				INTERNET/WEB SITE CHARGES			
v4-00100	1	Samsung Galaxy Tablets	2,367.21	30-401-740	Expenditure		32 1
				CAP PURCHASES-MAJOR EQUIP			
			<u>3,791.41</u>				
Checking Account Totals							
		<u>Paid</u>	<u>Void</u>	<u>Amount Paid</u>	<u>Amount Void</u>		
	Checks:	70	1	247,887.25	118.74		
	Direct Deposit:	0	0	0.00	0.00		
	Total:	<u>70</u>	<u>1</u>	<u>247,887.25</u>	<u>118.74</u>		
PLIGT							
1114	01/08/24	BOROU010 Borough of Carroll valley					44
v4-00105	1	Transfer for AP Dated 01/04/24	131,100.00	01-108-100	G/L		1 1
				CASH - F&M Bank MMA			

Check #	Check Date	Vendor	Amount Paid	Charge Account	Account Type	Reconciled/Void Contract	Ref Num	Ref Seq	Acct
PLIGT									
Continued									
Checking Account Totals			<u>Paid</u>	<u>Void</u>	<u>Amount Paid</u>		<u>Amount</u>	<u>Void</u>	
	Checks:		1	0	131,100.00		0.00		
	Direct Deposit:		0	0	0.00		0.00		
	Total:		<u>1</u>	<u>0</u>	<u>131,100.00</u>		<u>0.00</u>		
Report Totals									
	Checks:		71	1	378,987.25		118.74		
	Direct Deposit:		0	0	0.00		0.00		
	Total:		<u>71</u>	<u>1</u>	<u>378,987.25</u>		<u>118.74</u>		

Totals by Year-Fund					
Fund Description	Fund	Expend Total	Revenue Total	G/L Total	Total
CAPITAL RESERVE FUND	3-30	275.00	0.00	0.00	275.00
GENERAL FUND	4-01	148,558.84	0.00	141,209.26	289,768.10
SPECIAL EVENT FUND	4-04	1,160.00	0.00	0.00	1,160.00
SANITARY SEWER FUND	4-08	50,461.07	0.00	0.00	50,461.07
CAPITAL RESERVE FUND	4-30	<u>37,323.08</u>	<u>0.00</u>	<u>0.00</u>	<u>37,323.08</u>
Year Total:		<u>237,502.99</u>	<u>0.00</u>	<u>141,209.26</u>	<u>378,712.25</u>
Total of All Funds:		<u><u>237,777.99</u></u>	<u><u>0.00</u></u>	<u><u>141,209.26</u></u>	<u><u>378,987.25</u></u>

---

Totals by Fund					
Fund Description	Fund	Expend Total	Revenue Total	G/L Total	Total
GENERAL FUND	01	148,558.84	0.00	141,209.26	289,768.10
SPECIAL EVENT FUND	04	1,160.00	0.00	0.00	1,160.00
SANITARY SEWER FUND	08	50,461.07	0.00	0.00	50,461.07
CAPITAL RESERVE FUND	30	37,598.08	0.00	0.00	37,598.08
Total of All Funds:		<u>237,777.99</u>	<u>0.00</u>	<u>141,209.26</u>	<u>378,987.25</u>

Fund Description	Fund	Current	Prior Rcvd	Prior Open	Paid Prior	Fund Total
CAPITAL RESERVE FUND	3-30	275.00	0.00	0.00	0.00	275.00
GENERAL FUND	4-01	148,558.84	0.00	0.00	0.00	148,558.84
SPECIAL EVENT FUND	4-04	1,160.00	0.00	0.00	0.00	1,160.00
SANITARY SEWER FUND	4-08	50,461.07	0.00	0.00	0.00	50,461.07
CAPITAL RESERVE FUND	4-30	<u>37,323.08</u>	<u>0.00</u>	<u>0.00</u>	<u>0.00</u>	<u>37,323.08</u>
Year Total:		<u>237,502.99</u>	<u>0.00</u>	<u>0.00</u>	<u>0.00</u>	<u>237,502.99</u>
Total of All Funds:		<u><u>237,777.99</u></u>	<u><u>0.00</u></u>	<u><u>0.00</u></u>	<u><u>0.00</u></u>	<u><u>237,777.99</u></u>



---

MEMORANDUM

---

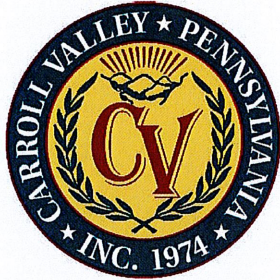

TO: BOROUGH COUNCIL; MAYOR  
FROM: DAVID HAZLETT, BOROUGH MANAGER  
SUBJECT: SURPLUS AUCTION SALES  
DATE: 2/8/2024  
CC: GAYLE MARTHERS

---

Staff is requesting the Council approve the listing and auctioning of the following items:

Select All

Activate Selected



**2014 DODGE CHARGER POLICE CRUISER HEMI** (62819856)

Ends: 2/22/2024 2:59:00 PM ET

Starting Bid: \$5,000.00

Activate Listing

Edit

List Similar

Delete



**2014 DODGE CHARGER POLICE CRUISER HEMI** (62815938)

Ends: 2/22/2024 1:16:00 PM ET

Starting Bid: \$5,000.00

Activate Listing

Edit

List Similar

Delete

## **INVITATION TO BID**

The Borough of Carroll Valley is accepting bids via [Municibid.com](https://Municibid.com) website for the following:

1. 2014 Dodge Charger
2. 2014 Dodge Charger

Anyone wishing to inspect any item(s) should contact the Borough Office at 717-642-8269.

The Borough of Carroll Valley does not provide any guaranties and/or warranties relative to the item(s) being sold. Thus, the item(s) is/are offered on an “AS IS – WHERE IS” basis. The Borough of Carroll Valley reserves the right to accept or reject any or all bids. ACCEPTABLE PAYMENT METHODS INCLUDE CASH, CREDIT CARD, AND CERTIFIED CHECK, and all Items MUST be paid for and picked up on or before Friday, March 1, 2024, at 2:00pm.

Gayle R. Marthers

Borough Secretary

---

---

**MEMORANDUM**

---

---



**TO:** BOROUGH COUNCIL; MAYOR  
**FROM:** DAVID HAZLETT, BOROUGH MANAGER  
**SUBJECT:** OFFICE OF OPEN RECORDS APPEAL  
**DATE:** 2/8/2024  
**CC:** GAYLE MARTHERS

Everyone,

Attached is a Final Determination of an appeal to the Office of Open Records submitted by Todd Mason, 8 North Trail. In it, Mr. Mason accused the Borough of withholding responsive records following a Right-to-Know Request.

The appeal was denied because Mr. Mason was given every document the Borough has in its possession.

It seems Mr. Mason is frustrated by his perception of my poor performance in the administration of Code Enforcement issues against his neighbor. He seems to believe that (1) I should have created a letter memorializing the property's code status and didn't, or (2) I did create a letter that I didn't disclose during the right-to-know request.

Had Mr. Mason asked me, I would have told him that neither of those beliefs was accurate. It is not our policy to memorialize, in writing, the disposition of a code enforcement issue with an individual property owner.



# pennsylvania

OFFICE OF OPEN RECORDS

**FINAL DETERMINATION**

IN THE MATTER OF

TODD MASON,  
Requester

v.

CARROLL VALLEY BOROUGH,  
Respondent

:  
:  
:  
:  
:  
:  
:  
:  
:  
:  
:  
:  
:  
:  
:  
:

: **Docket No: AP 2023-2934**

**FACTUAL BACKGROUND**

On November 8, 2023, Todd Mason (“Requester”) submitted a request (“Request”) to the Carroll Valley Borough (“Borough”) pursuant to the Right-to-Know Law (“RTKL”), 65 P.S. §§ 67.101 *et seq.*, seeking:

Any and all written communication between the borough and residents of 2 North Trl concerning Section 7474 of the borough's zoning code regulating the storage of heavy equipment on residential property.

Any and all written communication from the borough to the residents of 2 North Trl concerning the disposition of a letter dated October 19, 2022, revoking the home business permit at that address,

On November 16, 2023, the Borough purported to grant the Request in full, providing the Requester with responsive records.

On December 6, 2023, the Requester appealed to the Office of Open Records (“OOR”), arguing that the Borough had withheld responsive records to avoid discovery of its lax enforcement against a neighbor. On December 7, 2023, the OOR invited both parties to supplement the record and directed the Borough to notify any third parties of their ability to participate in this appeal. 65 P.S. § 67.1101(c).

On December 18, 2023, the Borough submitted a position statement arguing that it had provided the Requester with all responsive records. In support of this argument, the Borough submitted the attestation of David Hazlett, the Borough’s Open Records Officer, who attests that he conducted a search and provided all responsive records.

On January 19, 2024, the Requester submitted a position statement, arguing that additional records must exist because the Borough had not provided him with a disclosure of settlement/abandonment of the revocation of his neighbor’s home business permit and that the Borough’s failure to follow procedure constitutes bad faith in disclosures.

In response to a request for records, “an agency shall make a good faith effort to determine if...the agency has possession, custody or control of the record[.]” 65 P.S. § 67.901. While the RTKL does not define the term “good faith effort,” in *Uniontown Newspapers, Inc. v. Pa. Dep’t of Corr.*, the Commonwealth Court stated:

As part of a good faith search, the open records officer has a duty to advise all custodians of potentially responsive records about the request, and to obtain all potentially responsive records from those in possession... When records are not in an agency’s physical possession, an open records officer has a duty to contact agents within its control, including third-party contractors... After obtaining potentially responsive records, an agency has the duty to review the records and assess their public nature under...the RTKL.

185 A.3d 1161, 1171-72 (Pa. Commw. Ct. 2018) (citations omitted), *aff’d*, 243 A.3d 19 (Pa. 2020).

An agency must show, through detailed evidence submitted in good faith from individuals with

knowledge of the agency's records, that it has conducted a search reasonably calculated to uncover all relevant documents. *See Burr v. Pa. Dep't of Health*, OOR Dkt. AP 2021-0747, 2021 PA O.O.R.D. LEXIS 750; *see also Mollick v. Twp. of Worcester*, 32 A.3d 859, 875 (Pa. Commw. Ct. 2011).

Here, the Borough has submitted the affidavit of David Hazlett, who attests that upon receipt of the Request, he conducted a search through the Borough's records and contacted applicable Borough personnel. *See Hazlett Affidavit*, ¶¶ 4-5.<sup>1</sup> Mr. Hazlett affirms that all responsive records were located and provided to the Requester, and that no additional records exist within the possession, custody, or control of the Borough. *Hazlett Affidavit*, ¶ 6. As the Borough's Open Records Officer, Mr. Hazlett is familiar with the records of the Borough, and the record shows that he was able to provide a variety of responsive records. *Pa. Dep't of Health v. Mahon*, 283 A.3d 929 (Pa. Commw. Ct. 2022) (concluding that, in the absence of countervailing evidence, an agency may satisfy its burden of proving a record does not exist by submitting "either an unsworn attestation by the person who searched for the record or a sworn affidavit of nonexistence of the record"). Therefore, the Borough has submitted sufficient evidence to show that no additional responsive records exist. *Hodges v. Pa. Dep't of Health*, 29 A.3d 1190, 1192 (Pa. Commw. Ct. 2011).<sup>2</sup>

---

<sup>1</sup> Under the RTKL, a sworn affidavit or statement made under the penalty of perjury may serve as sufficient evidentiary support. *See Sherry v. Radnor Twp. Sch. Dist.*, 20 A.3d 515, 520-21 (Pa. Commw. Ct. 2011); *Moore v. Office of Open Records*, 992 A.2d 907, 909 (Pa. Commw. Ct. 2010). In the absence of any evidence that the Authority acted in bad faith or that the requested records exist, "the averments in [the statement] should be accepted as true." *McGowan v. Pa. Dep't of Envtl. Prot.*, 103 A.3d 374, 382-83 (Pa. Commw. Ct. 2014) (citing *Office of the Governor v. Scolforo*, 65 A.3d 1095, 1103 (Pa. Commw. Ct. 2013)).

<sup>2</sup> In response to the Borough's evidence, the Requester raises two arguments: first that the records should exist, pursuant to the Borough's own code, and second that the Borough has acted in bad faith by delaying action or updates regarding the status of his neighbor's business permit. The OOR, however, lacks the jurisdiction to determine whether the Borough has acted appropriately in regards to this permit, nor can it determine whether a record should exist. *Gorol v. Forest Hills Borough*, OOR Dkt. AP 2019-0329, 2019 PA O.O.R.D. LEXIS 427 ("While...evidence may establish that a [record] should exist, the OOR lacks jurisdiction to rule on the propriety of the lack of such [record]--the OOR may only determine whether a responsive record does, in fact, exist.").

## CONCLUSION

For the foregoing reasons, the appeal is **denied**, and the Borough is not required to take any further action. This Final Determination is binding on all parties. Within thirty days of the mailing date of this Final Determination, any party may appeal to the Adams County Court of Common Pleas. 65 P.S. § 67.1302(a). All parties must be served with notice of the appeal. The OOR also shall be served notice and have an opportunity to respond as per Section 1303 of the RTKL. 65 P.S. § 67.1303. However, as the quasi-judicial tribunal adjudicating this matter, the OOR is not a proper party to any appeal and should not be named as a party.<sup>3</sup> All documents or communications following the issuance of this Final Determination shall be sent to [oor-postfd@pa.gov](mailto:oor-postfd@pa.gov). This Final Determination shall be placed on the OOR website at: <http://openrecords.pa.gov>.

**FINAL DETERMINATION ISSUED AND MAILED: February 2, 2024**

*/s/ Jordan C. Davis*

---

JORDAN DAVIS  
SENIOR APPEALS OFFICER

Sent via electronic portal to:

Todd Mason;  
Zachary Rice, Esq.;  
David Hazlett

---

<sup>3</sup> *Padgett v. Pa. State Police*, 73 A.3d 644, 648 n.5 (Pa. Commw. Ct. 2013).

---

---

INTEROFFICE MEMORANDUM

---

---

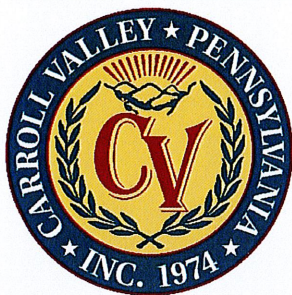

**TO:** BOROUGH COUNCIL  
**FROM:** DAVID A. HAZLETT, BOROUGH MANAGER  
**SUBJECT:** 23 SKYLARK TRAIL  
**DATE:** 02/09/2024  
**CC:** FILE

---

The Borough received a request from Nathan Bonner, Title Agent/Office Manager of Buchanan Settlement Services for a confirmatory deed to be recorded to correct the defective notary acknowledgment (notary date is prior to the document date) for a property transferred by the Borough in 2002. This will allow the conveyance of a clear title to the new buyer of the property. The attached Confirmatory Deed was provided by Mr. Bonner. The document has been reviewed by Borough Solicitor, Zachary Rice, and is before the Council for action.

**Action Requested:** I ask that you take action to authorize Mr. Mathews as Council President and Dr. Schubring as Council Vice President to sign the Confirmatory Deed for parcel # 43029-00046---000; Lot # B-0013 with address of 23 Skylark Trail, Carroll Valley Borough.



This Confirmatory Deed, made the \_\_\_\_\_ day of \_\_\_\_\_, 2024,

**Between**

**THE BOROUGH OF CARROLL VALLEY, a duly created and existing political subdivision located in Adams County, Pennsylvania;**

(hereinafter called the Grantor), of the one part, and

**DWAYNE F. ORNDORFF, of Emmitsburg, Frederick County, Maryland;**

(hereinafter called the Grantee), of the other part,

**Witnesseth**, that the said Grantor for and in consideration of the sum of **One And 00/100 Dollar (\$1.00)** lawful money of the United States of America, unto it well and truly paid by the said Grantee, at or before the sealing and delivery hereof, the receipt whereof is hereby acknowledged, has granted, bargained and sold, released and confirmed, and by these presents does grant, bargain and sell, release and confirm unto the said Grantee, as sole owner;

**ALL** that lot or ground situate in Carroll Valley Borough (formerly Liberty Township), Adams County, Pennsylvania, being Lot No. 13 in Section B, bounded and described as follows:

**BEGINNING** at a point in the center of Sky Lark Trail at Lot No. 12; thence by said lot, South 3 degrees 21 minutes 40 seconds East, 200 feet to Lot No. 54; thence by said lot, South 86 degrees 38 minutes 20 seconds West, 100 feet to Lot No. 14; thence by said lot, North 3 degrees 21 minutes 40 seconds West, 200 feet to a point in the center of said Sky Lark Trail; thence in said Sky Lark Trail, North 86 degrees 38 minutes 20 seconds East, 100 feet to the place of **BEGINNING**.

The above description was taken from a plan of lots labeled "Section B Supplemental, Charnita" and dated July 10, 1965, prepared by Gordon L. Brown, R.S., recorded in Adams County Miscellaneous Docket 4 at page 654.

**BEING** the premises which Martha J. Maxwell, now Martha Maxwell Spieth, and Walter Spieth, her husband, and George A. Maxwell, III, a single person, by Martha Jane Maxwell, his attorney-in-fact, by Deed dated October 14, 1997 and recorded in the Office of the Recorder of Deeds in and for Adams County, Pennsylvania, in Record Book 1473, Page 160, granted and conveyed unto The Borough of Carroll Valley **AND BEING** the premises which The Borough of Carroll Valley, a duly created and existing political subdivision located in Adams County, Pennsylvania, by Deed dated March 22, 2002 and recorded in the Office of the Recorder of Deeds in and for Adams County, Pennsylvania, in Record Book 2612, Page 191, granted and conveyed unto Dwayne F. Orndorff. This confirmatory deed is being done to correct a defective notary acknowledgment in the above recited deed.

**Under and Subject** to the following restrictions and conditions:

1. Said lot must be combined with the abutting property known as Lot B-012, and identified as Parcel 046 on County Tax Map 29 owned by the Grantee.
2. Said lot cannot be re-subdivided into a separate building lot.
3. Said lot shall not be developed with a principal use structure, namely a residential dwelling which could be used as a separate residence, but rather it shall be maintained and used principally as green space.

**Together with** all and singular the buildings and improvements, ways, streets, alleys, driveways, passages, waters, water-courses, rights, liberties, privileges, hereditaments and appurtenances, whatsoever unto the hereby granted premises belonging, or in anywise appertaining, and the reversions and remainders, rents, issues, and profits thereof; and all the estate, right, title, interest, property, claim and demand whatsoever of it, the said grantor, as well at law as in equity, of, in and to the same.

**To have and to hold** the said lot or piece of ground described above, with the buildings and improvements thereon erected, hereditaments and premises hereby granted, or mentioned and intended so to be, with the appurtenances, unto the said Grantee, his heirs and assigns, to and for the only proper use and behoof of the said Grantee, his heirs and assigns, forever.

**And** the said Grantor will warrant specially the property hereby conveyed.

**In Witness Whereof**, the party of the first part has hereunto set its hand and seal. Dated the day and year first above written.

**Sealed and Delivered**

IN THE PRESENCE OF US:

**THE BOROUGH OF CARROLL VALLEY**

BY: \_\_\_\_\_ (SEAL)  
**Richard Mathews, Council President**

BY: \_\_\_\_\_ (SEAL)  
**John Schubring, Council Vice-President**

Commonwealth of Pennsylvania } ss  
County of Franklin

On this the \_\_\_\_\_ day of \_\_\_\_\_, 2024, before me, the undersigned Notary Public, personally appeared **Richard Mathews and John Schubring**, who acknowledged themselves to be the **President and Vice-President of The Borough of Carroll Valley**, and that they as such Officers, being authorized to do so, executed the foregoing instrument for the purposes therein contained by signing the name of the Borough by themselves as President and Vice-President of the Borough Council.

IN WITNESS WHEREOF, I hereunto set my hand and official seal.

\_\_\_\_\_  
Notary Public  
My commission expires \_\_\_\_\_

The address of the above-named Grantee is:

**230 Depaul Street  
Emmitsburg, MD 21727**

\_\_\_\_\_  
On behalf of the Grantee

# UNFINISHED BUSINESS

---



February 6, 2024

# Memorandum

To: Carroll Valley Borough Council  
From: GMS Funding Solutions (GMS)

---

## **DCED – GREENWAYS, TRAILS AND RECREATION PROGRAM (GTRP)**

### *Carroll Valley Borough Trail Project*

Award: \$212,000

On Jan. 16, 2024 the Borough received notice that it received the full ask of \$212,000 for its GTRP grant application. The scope of work includes the construction of a 4,750 linear-foot trail at the project site (located between Deer Trail to the north, Fairfield Road (state Route 116) to the east, Skylark Trail to the south, and Veronica Trail to the west). The Borough published a press release and signed the grant agreement.

**Next Steps: The Borough should begin design of the project and, once designed, competitively bid the project to begin work. Invoices and proofs of payment for design and construction costs, when available, should be forwarded to GMS to submit reimbursement requests.**

## **H2O PA – WATER SUPPLY, SANITARY SEWER, AND STORM WATER PROJECTS (H2O)**

### *Wastewater Treatment Plant Upgrades*

Award: \$700,000

The fully executed second amendment for the H2O grant was received on Jan. 30, 2024. It extends the expiration date to June 30, 2025. The first Hickes Associates, Inc. invoice was received on Feb. 2, 2024, and once the invoice is paid and proof of payment is available, GMS will submit the second reimbursement request under the H2O grant.

**Next Steps: The Borough should forward the proof of payment for Hickes Associates first AFP once available. Continue to forward all engineering invoices and proof of payments to GMS. GMS will draft and submit the second reimbursement request once necessary invoices and proofs of payment are received.**

## **PENNVEST**

### *Wastewater Treatment Plant Upgrades*

Award: \$5,452,398 (loan)

The interest rate is 1.743 percent for years 1-5 and 2.179 percent for years 6-20. Loan signing occurred on Nov. 16, 2023. The pre-construction meeting was held on Dec. 11, 2023, at 10a.m. At this time, it is anticipated that the awarded contractor, Hickes Associates, Inc., will mobilize in the first quarter of 2024. GMS drafted the first reimbursement request on Feb. 2, 2023 for legal services in the amount of \$34,325. The designated signers (Council President and Borough Manager) should receive an email request to review, sign, and submit the reimbursement request.

**Next Steps: The Borough should review and submit the first reimbursement request. Once construction begins, the Borough should forward GMS the invoices and proofs of payment. Once the H2O grant is fully drawn down, PENNVEST reimbursement request submissions will begin.**

### **STATEWIDE LOCAL SHARE ACCOUNT (LSA)**

#### *Carroll Commons Park Improvements*

Request: \$276,000

The scope of work for the Statewide LSA includes construction of a pickleball court and relocated/expanded lighting, ADA compliant bathrooms, butterfly garden, EV charging stations, and installation of security cameras at the Carroll Commons Park. The grant application was submitted on Nov. 30, 2023, along with a letter of support from Rep. Moul and Sen. Mastriano. It is anticipated that awards will be made in late 2024 and GMS will continue to monitor this timeframe.

**Next Steps: GMS to monitor for when in 2024 awards will be announced. GMS will work with the Borough for any follow-up to the elected officials.**

### **COVID-19 ARPA STATE AND LOCAL FISCAL RECOVERY FUNDS (SLFRF)**

Award: \$206,303.02 (first tranche); \$206,303.02 (second tranche)

The next SLFRF report is due on April 30, 2024.

**Next steps: None at this time.**

### **PROJECTS/PROGRAMS TO MONITOR**

- Traffic light at the intersection of Routes 16 and 116
- Sports complex and recreation area construction on Borough-owned property along Routes 16 and 116 — planning document and construction of project. *GTRP is a potential program for the planning portion. Other funding sources may be options depending on what the planning document shows as a best fit (potentially RACP, GTRP, Statewide LSA)*
- Electric Vehicle Charging Stations (if Statewide LSA is not awarded or a smaller award is received)
- Water line extension along Country Club Trail
- Solar / alternative energy potential project

# NEW BUSINESS

---

**FOR YOUR INFORMATION**

---



**Municipal Services Report  
January 2024**

**Road Work and Right of Way: 411 Man-Hours**

- Road work performed included:
  - Repaired street sign at Pinehurst and Plainview trail intersection
  - Repaired (3) damaged mailboxes from snow plowing.
  - Cleared debris from storm grates.
  - Removed 5 fallen trees from Swallow Tr, Partridge Tr, Clipper Tr, and Little Tr
  - Repaired washed out area of roadway at Swallow and Stine trails intersection.
  - Cleaned several side ditches and culverts of leaves.
  - Replaced Street and the stop sign at Ranch Trail along with new posts.
  - Three (3) snow plowing events.

**Equipment Maintenance and Repair: 391 Man-Hours**

- Municipal Services/Parks/Zoning/STP Departments:
  - Calibrated Spinner, installed new Solenoid on plow, transported truck and plow to Rippeon Equip. in Frederick MD for repair. MS11 (2016 F-550 D/T)
  - Repaired Salt Spreader for sidewalks
  - Repaired Wiring for lights, transported truck to Martins Truck repair for transmission rebuild MS12 (2021 Mack D/T)
  - New plow cutting edges on MS6, MS8, MS10, MS11
  - Installed new wipers, Replaced blown coolant hose MS10 (2012 F-550)
  - Replaced Hydraulic coupler MS8 (2015 Mack D/T)
  - Replaced wiring for calcium pump MS6 (2012 International D/T)
  - New wheels, studs, and nuts MS3 (2010 F-550)
  - Replaced door handle, serviced truck, generator and boom MS5 (2001 GMC B/T)
  - Washed all plow vehicles after snow events.
  - 1500-hour service EQMS10 (JCB Backhoe)
  - Rotated tires MS2 (2010 Ford Expedition)

**Police Department: 22 Man-hours**

- Moved electronic speed sign.
- Fabricated brackets for PL49 and PL50 (2023 Dodge Durango's) Laptop docking stations.
- Serviced PL49 (2023 Dodge Durango)
- Changed punctured tire PL50 (2023 Dodge Durango)
- Transported police vehicles for calibration to Borough Office

**Parks and Property Maintenance: 182 Man-Hours**

- Borough office building
  - Removed holiday decorations.
  - Secured parking blocks in the parking lot
  - Snow removal and deicing
  - Cleaned and lubricated rear entrance door.
- Ranch Park
  - Weekly trash removal
  - Snow removal
- Carroll Commons Park
  - Trash removal.
  - Cleaning of the Cortner Pavilion after rentals
  - Rebuilt walking path after storm to repair washouts
- Lake Kay Mini Park
  - Weekly Trash collection and removal.
- Lake Mae/" New" property
  - Trash collection
- Municipal services facility
  - Cleaned breakroom and office area
  
- Other Borough Properties

**Admin, Events and Training: 35 Man-Hours**

- Attended Staff Meetings
- Issued driveway permits.
- Two employees performed random drug testing.
- Posted property for zoning board.
- Listed items on Municibid
- Ordered road salt, Cutting edges, snowplow replacement parts

**Sewer Treatment Plant: 6 Man-Hours**

- Assisted operator with replacing a pump in the Equalizing tanks.

- Prepped and painted shovels for groundbreaking of new plant

**Paid Time Off: 157 Man-Hours**

- 157 hours- Sick, Comp, Holiday, and Vacation leave

Respectfully Submitted,

**Brad A. Sanders**

Brad A. Sanders

MS Supervisor

Hours/Mileage January 2024				
Vehicle ID/ Equipment ID	Description	Beginning Miles/ Hours	Ending Miles/Hours	Total Miles/Hours
MS2	2010 Ford Expedition	86975	87647	672
MS3	2010 Ford F550 D/T	51593	52351	758
MS4	2001 Chevy B/T	82954	83025	71
MS5	2007 Freightliner Sweeper Truck	16149	16168	19
MS6	2012 INT 7400 D/T	13718	14025	307
MS7	1999 Int 5000 D/T	120946	121281	335
MS8	2015 Mack Granite	13907	14244	337
MS10	2012 Ford F550 D/T	78713	79433	720
MS 11	2016 Ford F550 D/t	39593	40364	771
MS12	2021 Mack Granite	2017	2322	305
Total Mileage				3623
EQMS2	2006 Bobcat Skid loader	894	Inoperable 06/2023	
EQMS3	2021 Volvo loader	168	237	69
EQMS4	580 John Deere 570B Grader	772	773	1
EQMS5	6110 John Deere Boom Mower	1692	1692	0
EQMS6	Bandit Brush Chipper	365	365	0
EQMS10	2019 JCB Backhoe	1472	1510	38
EQPK3	301A John Deere tractor	Hour meter inoperable		
EQPK7	John Deere Gator	89	94	5
EQPK8	2023 Scag Mower	55.4	55.4	0
EQPK 6	2018 Simplicity mower	530	530	0
Total Equipment hours				113



207 Baltimore Street  
Gettysburg, PA 17325  
Phone: 717-334-9137

[www.keller-engineers.com](http://www.keller-engineers.com)

1/22/2024

### **Carroll Valley WWTF Update**

- Project was bid and awarded to Hickes Associates Inc at \$5.315 Million
- Pre-Construction meeting was held 12/11/23.
- Pre-Construction meeting minutes were distributed on 12/12/23, Incl Kumar/Melissa Price
- Submittal Status Log distributed to Commission members.
- Still Finalizing Sanitaire Electrical and Liberty Pumps Submittals.
- Sanitaire MCC was approved as noted.
- Generator 360 kw resubmitted, previously Marathon, now Kohler. Advantage of slightly smaller footprint and earlier delivery date.
- Hickes providing 10 ft high double doors due to the building construction prior to generator delivery.
- First item of construction will be to install a temporary by-pass line to a proposed manhole followed by demolition of the lagoon This is scheduled to begin mid to end of February.
- Project completion date is expected to be January 2025.



# BOROUGH OF CARROLL VALLEY WWTP MONTHLY REPORT

Month- Jan 2024

Total Monthly Flow- 6.606 MGD

Average Monthly Flow- .213 MGD

Sludge Hauled- 27,500 Gal

Chlorine Usage- 160 Gal

Total Precipitation- 7.45"

## Work Conducted and Comments

- There was 1 major rain event that put the plant into hydraulic overload conditions for 3 days. Due to the wet weather the whole month and liberty being busy our flow will show for Jan we were hydraulically overloaded.
- Cleaned the chlorine contact tanks 3 times due to excessive flows.
- The Clarifier drive unit broke down. Installed a spare that was in storage. Removed and replaced the broken flight that caused the breakdown.
- Visually inspected all manholes in both J and K sections looking for I&I issues. Nothing major was found, only a few minor fixes that I can complete once ground dries out.
- There was 2 callouts for power outage and the generator needed attention.



SUPPLEMENTAL REPORT  
DAILY EFFLUENT MONITORING

Facility Name: Carroll Valley STP  
Municipality: Borough of Carroll Valley  
Watershed: Adams  
Laboratories: LABS Inc.  
Month: 1 (select number)  
Year: 2024  
Permit No.: PA0080039 A-1  
Outfall: 001  
Renewal application due 180 days prior to expiration.  
This permit will expire on: Completion of Construction

Table with columns: Week, Day, Stage, Date, Flow (MGD), pH, Dissolved Oxygen (mg/L), TRC (mg/L), CBOD5 (mg/L), TSS (mg/L), Fecal Coliform (No.), Fecal Coliform (No.), NH3-N (mg/L), NH3-N (mg/L), BOD5 (mg/L), TSS (mg/L), Rainfall (in). Rows include weekly data for weeks 1-5 and a summary section for DMR statistics.

I certify under penalty of law that this document was prepared under my direction or supervision in accordance with a system designed to assure that qualified personnel gather and evaluate the information submitted. Based on my review and the information submitted, I am aware that there are no significant violations of the permit conditions, and that the information is true, accurate and complete. I am aware that there are significant penalties for submitting false information, including the possibility of fine and imprisonment for knowing violations. See 18 Pa. C.S. § 4904 (relating to unsworn falsification).

Prepared By: Jecidiah D Fetter  
Title: Chief Operator  
License No.: S17793  
Date: 1/31/2024

**- Pump Calculations for Carroll Valley Borough -  
Liberty Pump Station  
Monday, January 1, 2024 to Wednesday, January 31, 2024**

<b>- Date Range Statistics -</b>								
Pump	AVG Cycles	Total Cycles	AVG Draw Down	AVG Runtime	Total Runtime	AVG GPM	AVG Effluent	Total Effluent
1	5	181	00:05:15	00:30:41	15:51:41	152	4,822	149,511
2	5	181	00:05:15	00:30:44	15:52:44	150	4,747	147,171
3	0	0	00:00:00	00:00:00	00:00:00	0	0	0
Station:							9,569	296,682

<b>- Pump Calculations -</b>								
Device	Num	Station	Pump	Cycles	AVG Draw Down	Runtime	AVG GPM	Effluent
<b>Date: 1/31/2024</b>								
38033		Liberty Pump Station	1	4	00:04:09	00:16:37	185	3,074
38033		Liberty Pump Station	2	3	00:04:42	00:14:07	163	2,301
38033		Liberty Pump Station	3	0	00:00:00	00:00:00	0	0
Station:							5,375	
<b>Date: 1/30/2024</b>								
38033		Liberty Pump Station	1	5	00:04:33	00:22:49	172	3,924
38033		Liberty Pump Station	2	7	00:04:55	00:34:29	158	5,448
38033		Liberty Pump Station	3	0	00:00:00	00:00:00	0	0
Station:							9,372	
<b>Date: 1/29/2024</b>								
38033		Liberty Pump Station	1	11	00:05:03	00:55:38	167	9,290
38033		Liberty Pump Station	2	10	00:05:13	00:52:13	159	8,302
38033		Liberty Pump Station	3	0	00:00:00	00:00:00	0	0
Station:							17,592	
<b>Date: 1/28/2024</b>								
38033		Liberty Pump Station	1	12	00:05:28	01:05:39	159	10,438
38033		Liberty Pump Station	2	13	00:05:26	01:10:43	158	11,173
38033		Liberty Pump Station	3	0	00:00:00	00:00:00	0	0
Station:							21,611	



**- Pump Calculations -**

Device	Num	Station	Pump	Cycles	AVG Draw Down	Runtime	AVG GPM	Effluent
Date: 1/27/2024								
38033		Liberty Pump Station	1	8	00:05:06	00:40:52	155	6,334
38033		Liberty Pump Station	2	7	00:05:12	00:36:24	153	5,569
38033		Liberty Pump Station	3	0	00:00:00	00:00:00	0	0
							Station:	11,903
Date: 1/26/2024								
38033		Liberty Pump Station	1	3	00:04:58	00:14:54	155	2,309
38033		Liberty Pump Station	2	4	00:05:00	00:20:00	152	3,040
38033		Liberty Pump Station	3	0	00:00:00	00:00:00	0	0
							Station:	5,349
Date: 1/25/2024								
38033		Liberty Pump Station	1	1	00:04:49	00:04:49	158	761
38033		Liberty Pump Station	2	0	00:00:00	00:00:00	0	0
38033		Liberty Pump Station	3	0	00:00:00	00:00:00	0	0
							Station:	761
Date: 1/24/2024								
38033		Liberty Pump Station	1	7	00:04:54	00:34:21	158	5,427
38033		Liberty Pump Station	2	7	00:04:58	00:34:52	155	5,404
38033		Liberty Pump Station	3	0	00:00:00	00:00:00	0	0
							Station:	10,831
Date: 1/23/2024								
38033		Liberty Pump Station	1	6	00:05:06	00:30:36	158	4,834
38033		Liberty Pump Station	2	7	00:04:55	00:34:25	156	5,369
38033		Liberty Pump Station	3	0	00:00:00	00:00:00	0	0
							Station:	10,203
Date: 1/22/2024								
38033		Liberty Pump Station	1	17	00:05:51	01:39:37	162	16,137
38033		Liberty Pump Station	2	16	00:05:49	01:33:12	150	13,980

**- Pump Calculations -**

Device	Num	Station	Pump	Cycles	AVG Draw Down	Runtime	AVG GPM	Effluent
38033		Liberty Pump Station	3	0	00:00:00	00:00:00	0	0
							Station:	30,117
Date: 1/21/2024								
38033		Liberty Pump Station	1	16	00:06:01	01:36:20	155	14,931
38033		Liberty Pump Station	2	16	00:05:58	01:35:29	153	14,608
38033		Liberty Pump Station	3	0	00:00:00	00:00:00	0	0
							Station:	29,539
Date: 1/20/2024								
38033		Liberty Pump Station	1	9	00:05:22	00:48:20	155	7,491
38033		Liberty Pump Station	2	9	00:05:26	00:48:54	153	7,481
38033		Liberty Pump Station	3	0	00:00:00	00:00:00	0	0
							Station:	14,972
Date: 1/19/2024								
38033		Liberty Pump Station	1	4	00:04:54	00:19:37	155	3,040
38033		Liberty Pump Station	2	5	00:04:54	00:24:31	156	3,824
38033		Liberty Pump Station	3	0	00:00:00	00:00:00	0	0
							Station:	6,864
Date: 1/18/2024								
38033		Liberty Pump Station	1	4	00:05:01	00:20:07	156	3,138
38033		Liberty Pump Station	2	4	00:04:54	00:19:36	156	3,057
38033		Liberty Pump Station	3	0	00:00:00	00:00:00	0	0
							Station:	6,195
Date: 1/17/2024								
38033		Liberty Pump Station	1	5	00:04:56	00:24:40	160	3,946
38033		Liberty Pump Station	2	5	00:05:03	00:25:16	152	3,840
38033		Liberty Pump Station	3	0	00:00:00	00:00:00	0	0
							Station:	7,786
Date: 1/16/2024								
38033		Liberty Pump Station	1	9	00:05:08	00:46:17	155	7,173

- Pump Calculations -								
Device	Num	Station	Pump	Cycles	AVG Draw Down	Runtime	AVG GPM	Effluent
38033		Liberty Pump Station	2	8	00:05:08	00:41:07	155	6,373
38033		Liberty Pump Station	3	0	00:00:00	00:00:00	0	0
							Station:	13,546
Date: 1/15/2024								
38033		Liberty Pump Station	1	8	00:05:33	00:44:26	152	6,753
38033		Liberty Pump Station	2	9	00:05:16	00:47:31	155	7,365
38033		Liberty Pump Station	3	0	00:00:00	00:00:00	0	0
							Station:	14,118
Date: 1/14/2024								
38033		Liberty Pump Station	1	8	00:05:08	00:41:04	152	6,242
38033		Liberty Pump Station	2	7	00:05:06	00:35:43	156	5,571
38033		Liberty Pump Station	3	0	00:00:00	00:00:00	0	0
							Station:	11,813
Date: 1/13/2024								
38033		Liberty Pump Station	1	5	00:05:12	00:26:01	152	3,954
38033		Liberty Pump Station	2	6	00:05:05	00:30:34	154	4,707
38033		Liberty Pump Station	3	0	00:00:00	00:00:00	0	0
							Station:	8,661
Date: 1/12/2024								
38033		Liberty Pump Station	1	5	00:05:10	00:25:50	148	3,823
38033		Liberty Pump Station	2	4	00:04:55	00:19:43	156	3,075
38033		Liberty Pump Station	3	0	00:00:00	00:00:00	0	0
							Station:	6,898
Date: 1/11/2024								
38033		Liberty Pump Station	1	6	00:05:07	00:30:43	154	4,730
38033		Liberty Pump Station	2	6	00:05:08	00:30:49	149	4,591
38033		Liberty Pump Station	3	0	00:00:00	00:00:00	0	0
							Station:	9,321
Date: 1/10/2024								

**- Pump Calculations -**

Device	Num	Station	Pump	Cycles	AVG Draw Down	Runtime	AVG GPM	Effluent
38033		Liberty Pump Station	1	11	00:05:27	01:00:03	149	8,947
38033		Liberty Pump Station	2	11	00:05:20	00:58:47	156	9,170
38033		Liberty Pump Station	3	0	00:00:00	00:00:00	0	0
							Station:	18,117
Date: 1/9/2024								
38033		Liberty Pump Station	1	3	00:04:54	00:14:42	156	2,293
38033		Liberty Pump Station	2	4	00:05:14	00:20:59	148	3,105
38033		Liberty Pump Station	3	0	00:00:00	00:00:00	0	0
							Station:	5,398
Date: 1/8/2024								
38033		Liberty Pump Station	1	5	00:05:01	00:25:06	154	3,865
38033		Liberty Pump Station	2	4	00:05:06	00:20:25	152	3,103
38033		Liberty Pump Station	3	0	00:00:00	00:00:00	0	0
							Station:	6,968
Date: 1/7/2024								
38033		Liberty Pump Station	1	1	00:04:37	00:04:37	159	734
38033		Liberty Pump Station	2	1	00:04:51	00:04:51	158	766
38033		Liberty Pump Station	3	0	00:00:00	00:00:00	0	0
							Station:	1,500
Date: 1/6/2024								
38033		Liberty Pump Station	1	1	00:04:44	00:04:44	158	747
38033		Liberty Pump Station	2	1	00:04:59	00:04:59	158	787
38033		Liberty Pump Station	3	0	00:00:00	00:00:00	0	0
							Station:	1,534
Date: 1/5/2024								
38033		Liberty Pump Station	1	1	00:04:33	00:04:33	158	718
38033		Liberty Pump Station	2	2	00:04:30	00:09:01	159	1,433
38033		Liberty Pump Station	3	0	00:00:00	00:00:00	0	0

**- Pump Calculations -**

Device	Num	Station	Pump	Cycles	AVG Draw Down	Runtime	AVG GPM	Effluent
							Station:	2,151
Date: 1/4/2024								
38033		Liberty Pump Station	1	2	00:04:44	00:09:28	156	1,476
38033		Liberty Pump Station	2	1	00:04:52	00:04:52	155	754
38033		Liberty Pump Station	3	0	00:00:00	00:00:00	0	0
							Station:	2,230
Date: 1/3/2024								
38033		Liberty Pump Station	1	0	00:00:00	00:00:00	0	0
38033		Liberty Pump Station	2	1	00:04:47	00:04:47	155	741
38033		Liberty Pump Station	3	0	00:00:00	00:00:00	0	0
							Station:	741
Date: 1/2/2024								
38033		Liberty Pump Station	1	2	00:04:46	00:09:32	156	1,487
38033		Liberty Pump Station	2	1	00:04:47	00:04:47	155	741
38033		Liberty Pump Station	3	0	00:00:00	00:00:00	0	0
							Station:	2,228
Date: 1/1/2024								
38033		Liberty Pump Station	1	2	00:04:49	00:09:39	155	1,495
38033		Liberty Pump Station	2	2	00:04:49	00:09:38	155	1,493
38033		Liberty Pump Station	3	0	00:00:00	00:00:00	0	0
							Station:	2,988

**- Pump Calculations for Carroll Valley Borough -  
Sanders Pump Station  
Monday, January 1, 2024 to Wednesday, January 31, 2024**

<b>- Date Range Statistics -</b>								
Pump	AVG Cycles	Total Cycles	AVG Draw Down	AVG Runtime	Total Runtime	AVG GPM	AVG Effluent	Total Effluent
1	69	2,144	00:01:29	01:43:04	53:15:15	451	49,166	1,524,172
2	69	2,148	00:01:25	01:39:15	51:16:58	451	46,649	1,446,148
3	69	2,141	00:01:23	01:36:17	49:45:00	456	45,451	1,408,991
						Station:	141,266	4,379,311

<b>- Pump Calculations -</b>								
Device	Num	Station	Pump	Cycles	AVG Draw Down	Runtime	AVG GPM	Effluent
<b>Date: 1/31/2024</b>								
37005		Sanders Pump Station	1	86	00:01:26	02:03:46	437	54,086
37005		Sanders Pump Station	2	87	00:01:26	02:04:44	436	54,383
37005		Sanders Pump Station	3	87	00:01:25	02:03:28	449	55,436
							Station:	163,905
<b>Date: 1/30/2024</b>								
37005		Sanders Pump Station	1	99	00:01:31	02:30:16	448	67,319
37005		Sanders Pump Station	2	98	00:01:31	02:29:01	449	66,908
37005		Sanders Pump Station	3	99	00:01:29	02:27:34	450	66,405
							Station:	200,632
<b>Date: 1/29/2024</b>								
37005		Sanders Pump Station	1	112	00:01:41	03:10:04	464	88,190
37005		Sanders Pump Station	2	113	00:01:40	03:09:50	464	88,082
37005		Sanders Pump Station	3	112	00:01:39	03:05:59	468	87,040
							Station:	263,312
<b>Date: 1/28/2024</b>								
37005		Sanders Pump Station	1	66	00:01:23	01:31:44	418	38,344
37005		Sanders Pump Station	2	65	00:01:22	01:29:02	425	37,839
37005		Sanders Pump Station	3	65	00:01:21	01:27:45	425	37,293
							Station:	113,476

- Pump Calculations -								
Device	Num	Station	Pump	Cycles	AVG Draw Down	Runtime	AVG GPM	Effluent
Date: 1/27/2024								
37005		Sanders Pump Station	1	66	00:01:22	01:30:12	424	38,244
37005		Sanders Pump Station	2	66	00:01:21	01:30:01	424	38,167
37005		Sanders Pump Station	3	66	00:01:21	01:29:09	433	38,601
							Station:	115,012
Date: 1/26/2024								
37005		Sanders Pump Station	1	60	00:01:20	01:20:28	427	34,359
37005		Sanders Pump Station	2	60	00:01:20	01:20:57	423	34,241
37005		Sanders Pump Station	3	61	00:01:19	01:20:25	428	34,418
							Station:	103,018
Date: 1/25/2024								
37005		Sanders Pump Station	1	51	00:01:18	01:06:40	424	28,266
37005		Sanders Pump Station	2	52	00:01:18	01:08:09	420	28,623
37005		Sanders Pump Station	3	51	00:01:17	01:05:48	426	28,030
							Station:	84,919
Date: 1/24/2024								
37005		Sanders Pump Station	1	48	00:01:17	01:01:43	419	25,859
37005		Sanders Pump Station	2	47	00:01:17	01:00:34	421	25,498
37005		Sanders Pump Station	3	48	00:01:16	01:01:06	425	25,967
							Station:	77,324
Date: 1/23/2024								
37005		Sanders Pump Station	1	49	00:01:16	01:02:41	422	26,452
37005		Sanders Pump Station	2	50	00:01:16	01:03:36	426	27,093
37005		Sanders Pump Station	3	49	00:01:15	01:01:29	430	26,437
							Station:	79,982
Date: 1/22/2024								
37005		Sanders Pump Station	1	56	00:01:16	01:11:27	433	30,937
37005		Sanders Pump Station	2	55	00:01:16	01:10:02	431	30,184

- Pump Calculations -								
Device	Num	Station	Pump	Cycles	AVG Draw Down	Runtime	AVG GPM	Effluent
37005		Sanders Pump Station	3	55	00:01:15	01:09:08	438	30,280
							Station:	91,401
Date: 1/21/2024								
37005		Sanders Pump Station	1	57	00:01:16	01:12:32	430	31,189
37005		Sanders Pump Station	2	57	00:01:16	01:12:23	435	31,486
37005		Sanders Pump Station	3	57	00:01:15	01:11:17	443	31,578
							Station:	94,253
Date: 1/20/2024								
37005		Sanders Pump Station	1	60	00:01:16	01:16:25	439	33,546
37005		Sanders Pump Station	2	61	00:01:16	01:17:34	436	33,819
37005		Sanders Pump Station	3	61	00:01:15	01:16:50	446	34,267
							Station:	101,632
Date: 1/19/2024								
37005		Sanders Pump Station	1	62	00:01:16	01:18:36	444	34,898
37005		Sanders Pump Station	2	61	00:01:15	01:17:07	443	34,162
37005		Sanders Pump Station	3	61	00:01:15	01:17:11	449	34,655
							Station:	103,715
Date: 1/18/2024								
37005		Sanders Pump Station	1	67	00:01:16	01:25:11	449	38,247
37005		Sanders Pump Station	2	68	00:01:16	01:27:11	452	39,406
37005		Sanders Pump Station	3	67	00:01:16	01:24:52	454	38,529
							Station:	116,182
Date: 1/17/2024								
37005		Sanders Pump Station	1	74	00:01:17	01:35:23	449	42,827
37005		Sanders Pump Station	2	73	00:01:17	01:34:11	453	42,665
37005		Sanders Pump Station	3	74	00:01:16	01:34:23	458	43,227
							Station:	128,719
Date: 1/16/2024								
37005		Sanders Pump Station	1	86	00:01:19	01:53:39	457	51,938



- Pump Calculations -								
Device	Num	Station	Pump	Cycles	AVG Draw Down	Runtime	AVG GPM	Effluent
37005		Sanders Pump Station	2	86	00:01:18	01:52:58	455	51,399
37005		Sanders Pump Station	3	85	00:01:17	01:50:27	464	51,248
							Station:	154,585
Date: 1/15/2024								
37005		Sanders Pump Station	1	103	00:01:25	02:26:15	475	69,468
37005		Sanders Pump Station	2	103	00:01:24	02:24:32	478	69,086
37005		Sanders Pump Station	3	102	00:01:22	02:19:37	481	67,155
							Station:	205,709
Date: 1/14/2024								
37005		Sanders Pump Station	1	122	00:01:30	03:03:12	489	89,584
37005		Sanders Pump Station	2	121	00:01:29	03:01:01	494	89,422
37005		Sanders Pump Station	3	122	00:01:28	02:59:02	496	88,800
							Station:	267,806
Date: 1/13/2024								
37005		Sanders Pump Station	1	99	00:01:22	02:16:56	541	74,080
37005		Sanders Pump Station	2	99	00:01:23	02:17:22	550	75,551
37005		Sanders Pump Station	3	98	00:01:21	02:12:49	547	72,650
							Station:	222,281
Date: 1/12/2024								
37005		Sanders Pump Station	1	111	00:01:25	02:37:45	482	76,035
37005		Sanders Pump Station	2	111	00:01:24	02:37:13	485	76,250
37005		Sanders Pump Station	3	111	00:01:23	02:35:14	487	75,598
							Station:	227,883
Date: 1/11/2024								
37005		Sanders Pump Station	1	134	00:01:41	03:46:27	509	115,263
37005		Sanders Pump Station	2	135	00:01:40	03:46:44	510	115,634
37005		Sanders Pump Station	3	134	00:01:38	03:40:23	522	115,040
							Station:	345,937
Date: 1/10/2024								

- Pump Calculations -								
Device	Num	Station	Pump	Cycles	AVG Draw Down	Runtime	AVG GPM	Effluent
37005		Sanders Pump Station	1	66	00:04:44	05:13:25	683	214,063
37005		Sanders Pump Station	2	71	00:02:51	03:22:45	669	135,639
37005		Sanders Pump Station	3	66	00:02:21	02:35:51	675	105,198
							Station:	454,900
Date: 1/9/2024								
37005		Sanders Pump Station	1	49	00:01:16	01:02:04	431	26,750
37005		Sanders Pump Station	2	49	00:01:15	01:02:03	431	26,743
37005		Sanders Pump Station	3	49	00:01:15	01:01:41	434	26,770
							Station:	80,263
Date: 1/8/2024								
37005		Sanders Pump Station	1	52	00:01:16	01:06:32	426	28,343
37005		Sanders Pump Station	2	52	00:01:17	01:06:48	427	28,523
37005		Sanders Pump Station	3	52	00:01:16	01:05:54	430	28,337
							Station:	85,203
Date: 1/7/2024								
37005		Sanders Pump Station	1	43	00:01:15	00:54:21	428	23,261
37005		Sanders Pump Station	2	42	00:01:16	00:53:16	423	22,531
37005		Sanders Pump Station	3	43	00:01:14	00:53:40	432	23,184
							Station:	68,976
Date: 1/6/2024								
37005		Sanders Pump Station	1	40	00:01:16	00:50:40	414	20,976
37005		Sanders Pump Station	2	41	00:01:16	00:51:57	415	21,559
37005		Sanders Pump Station	3	40	00:01:15	00:50:00	420	21,000
							Station:	63,535
Date: 1/5/2024								
37005		Sanders Pump Station	1	42	00:01:15	00:52:43	428	22,562
37005		Sanders Pump Station	2	41	00:01:15	00:51:31	426	21,946
37005		Sanders Pump Station	3	41	00:01:14	00:51:05	430	21,965

- Pump Calculations -								
Device	Num	Station	Pump	Cycles	AVG Draw Down	Runtime	AVG GPM	Effluent
							Station:	66,473
Date: 1/4/2024								
37005		Sanders Pump Station	1	42	00:01:15	00:52:59	425	22,517
37005		Sanders Pump Station	2	42	00:01:15	00:52:53	425	22,475
37005		Sanders Pump Station	3	43	00:01:14	00:53:38	429	23,008
							Station:	68,000
Date: 1/3/2024								
37005		Sanders Pump Station	1	44	00:01:15	00:55:37	422	23,470
37005		Sanders Pump Station	2	45	00:01:16	00:57:04	426	24,310
37005		Sanders Pump Station	3	44	00:01:15	00:55:06	432	23,803
							Station:	71,583
Date: 1/2/2024								
37005		Sanders Pump Station	1	49	00:01:16	01:02:34	424	26,528
37005		Sanders Pump Station	2	48	00:01:16	01:01:22	426	26,142
37005		Sanders Pump Station	3	48	00:01:15	01:00:31	428	25,901
							Station:	78,571
Date: 1/1/2024								
37005		Sanders Pump Station	1	49	00:01:17	01:02:58	422	26,571
37005		Sanders Pump Station	2	49	00:01:17	01:03:07	418	26,382
37005		Sanders Pump Station	3	50	00:01:16	01:03:38	427	27,171
							Station:	80,124

# Station Effluent (Outflow)

Mon. 1/1/24 to Wed. 1/31/24

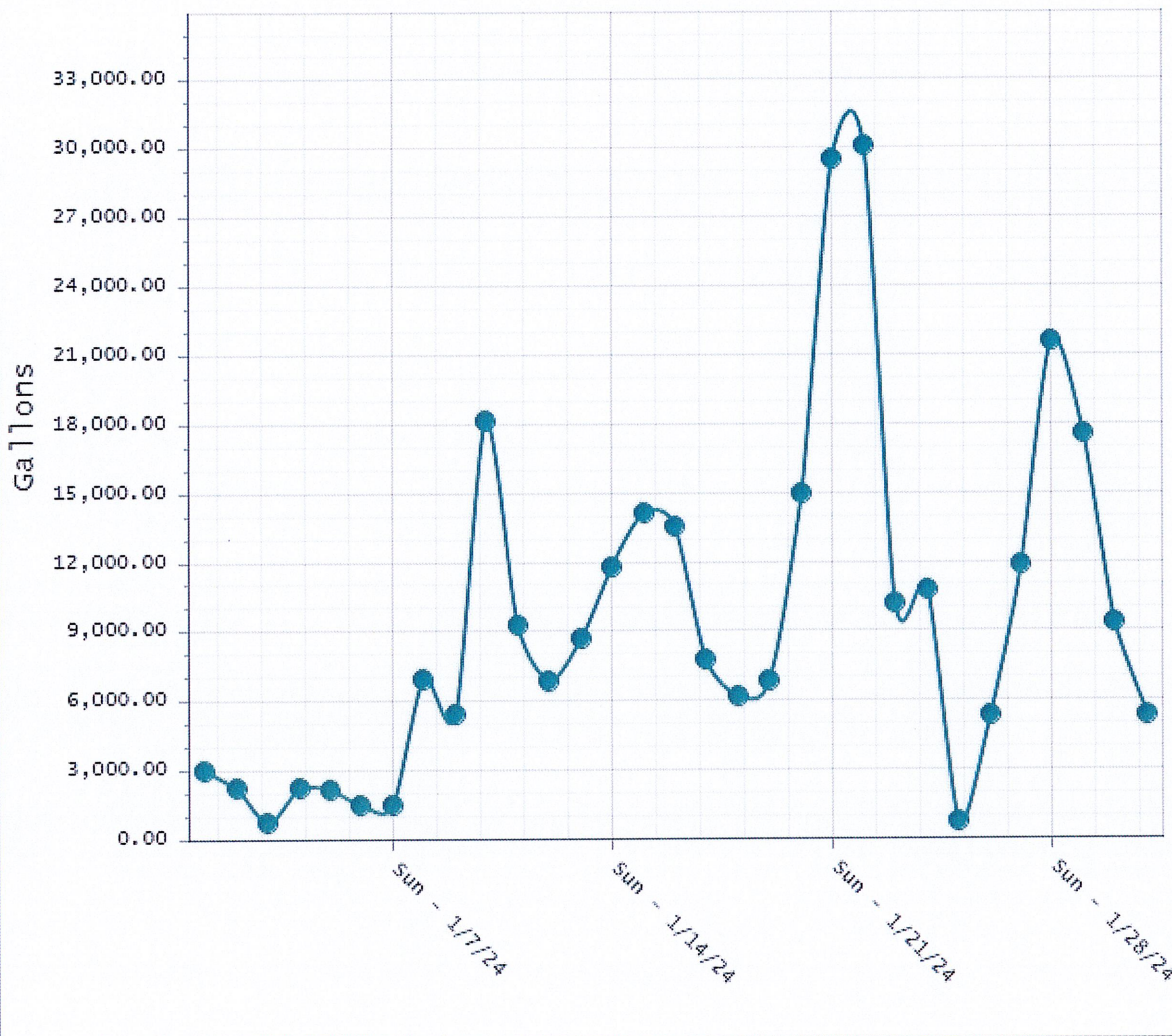

# Station Effluent (Outflow)

Mon. 1/1/24 to wed. 1/31/24

